

Centrometal

HEATING TECHNIQUE

Centrometal d.o.o. - Glavna 12, 40306 Macinec, Croatia, tel: +385 40 372 600, fax: +385 40 372 611

ENG

Technical instructions



using of **REGULATION**
hot water boiler PelTec / PelTec-lambda



THE FIRST START-UP MUST BE DONE BY AUTHORIZED PERSON
OTHERWISE PRODUCT WARRANTY IS NOT VALID

PelTec 12-48

PelTec-lambda 12-96

SWITCHING ON

After turning on the main switch, screen will display language selection menu and software version. You can choose between 12 languages, Croatian, French, Portuguese, English, Slovenian, Italian, Serbian, German, Czech, Hungarian, Slovakian and Spanish. To select the language, press the flag of language you want.



If the language selection is "disabled" (display -> language sel -> disabled), initial message will appear in the screen as long as the set in the menu "Welcome time" (display -> welcome time).

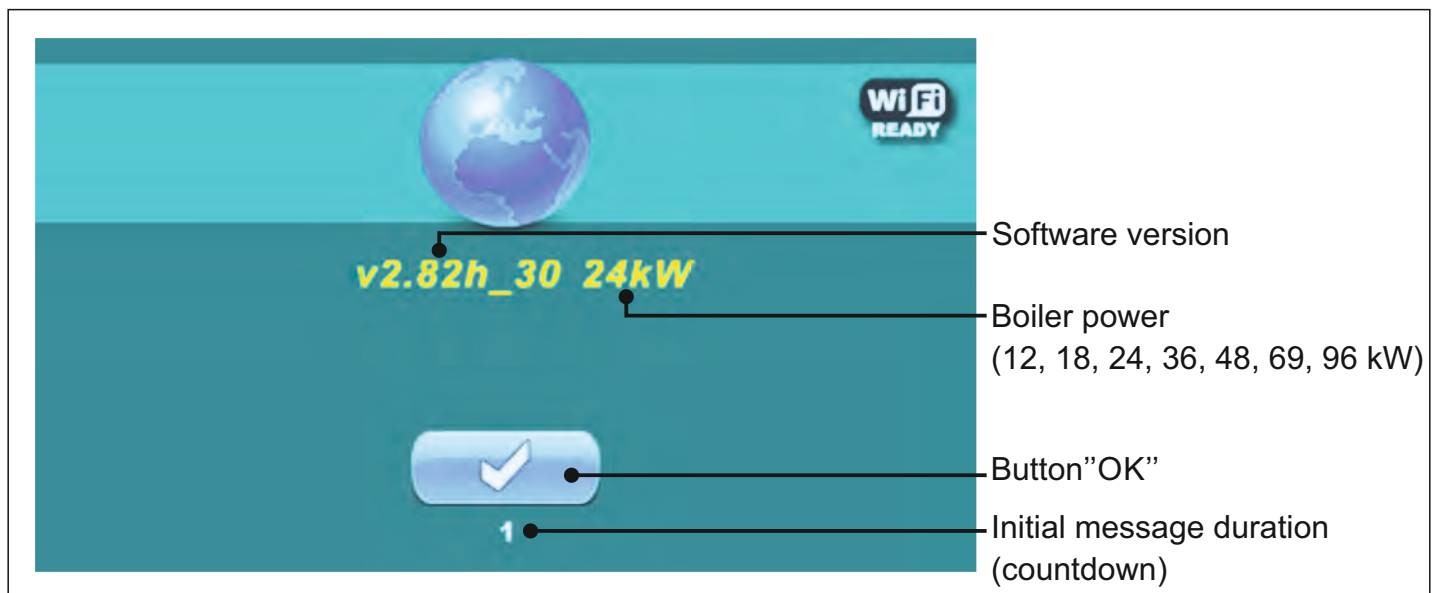

When turning the main switch the screen should not be pressed (by finger ...). If the screen when you turn the main switch is pressed (on the screen labeled "Firmware update ") regulation is in "software update" that can be used by authorized personnel only. If this happens, it is necessary to turn off the main switch and restarted without any pressure on the display.

MAIN MENU

The main menu is used to select the desired submenu. To select a specific menu you must press the appropriate icon on the screen. To switch between the "Main menu" and "Boiler working display" press the button "Display selection". To switch between graphic and numeric display of the boiler using press "Boiler operation display".

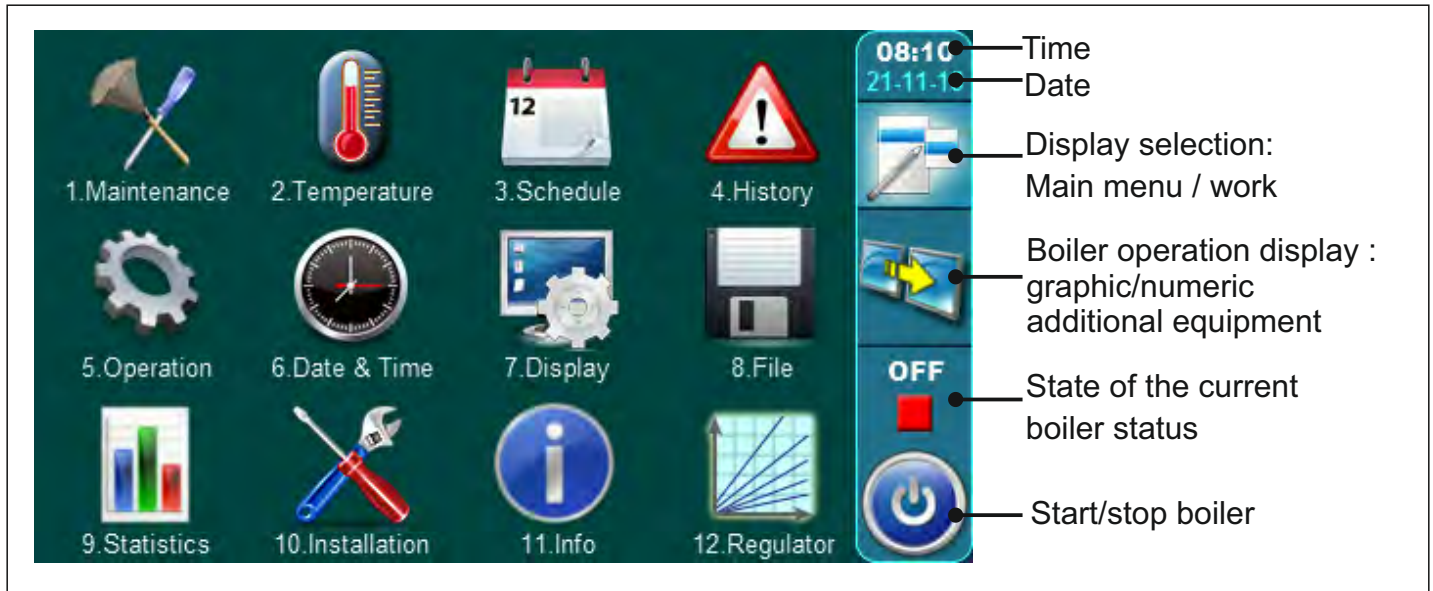

BUTTONS

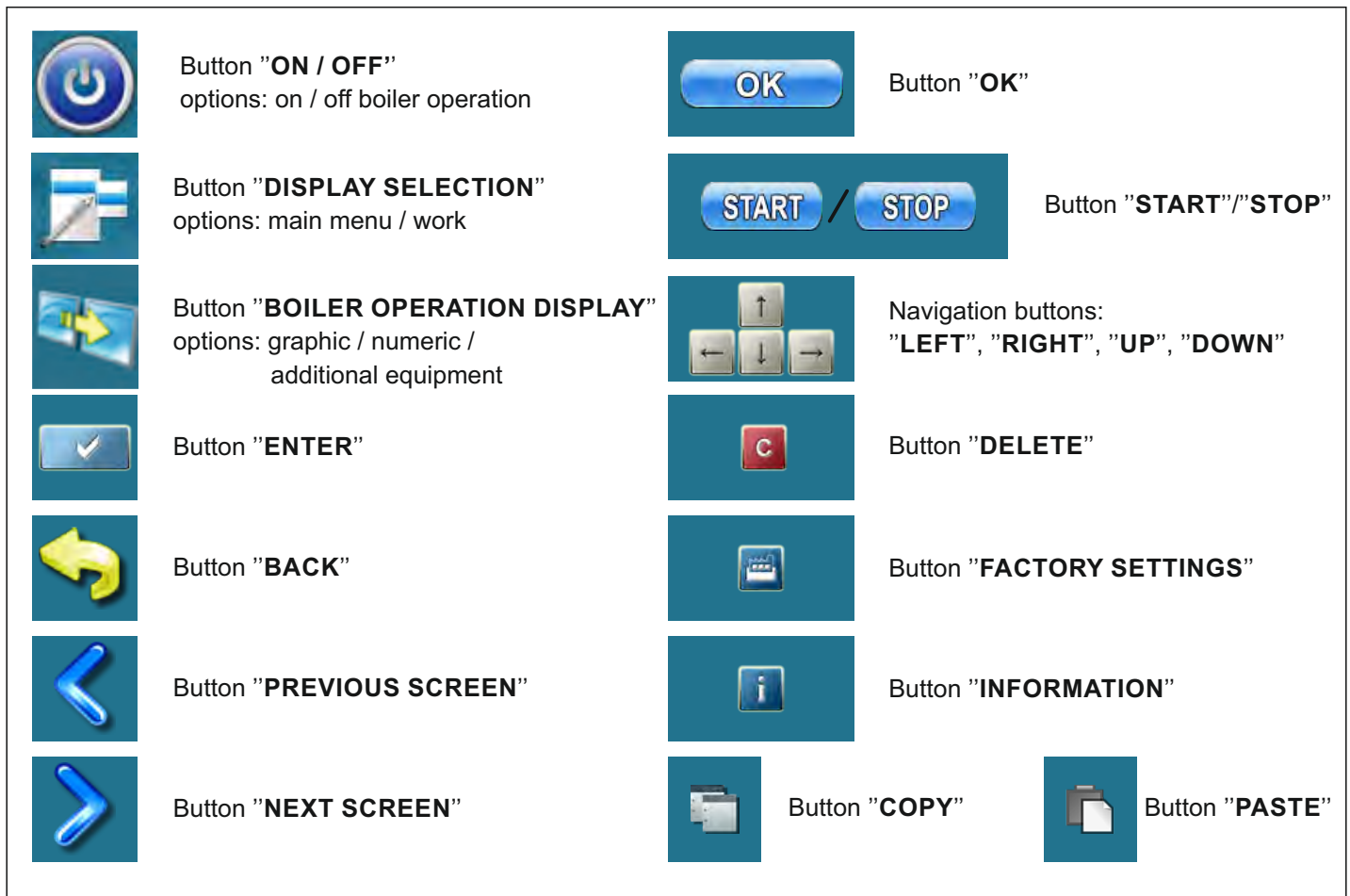

SYMBOLS

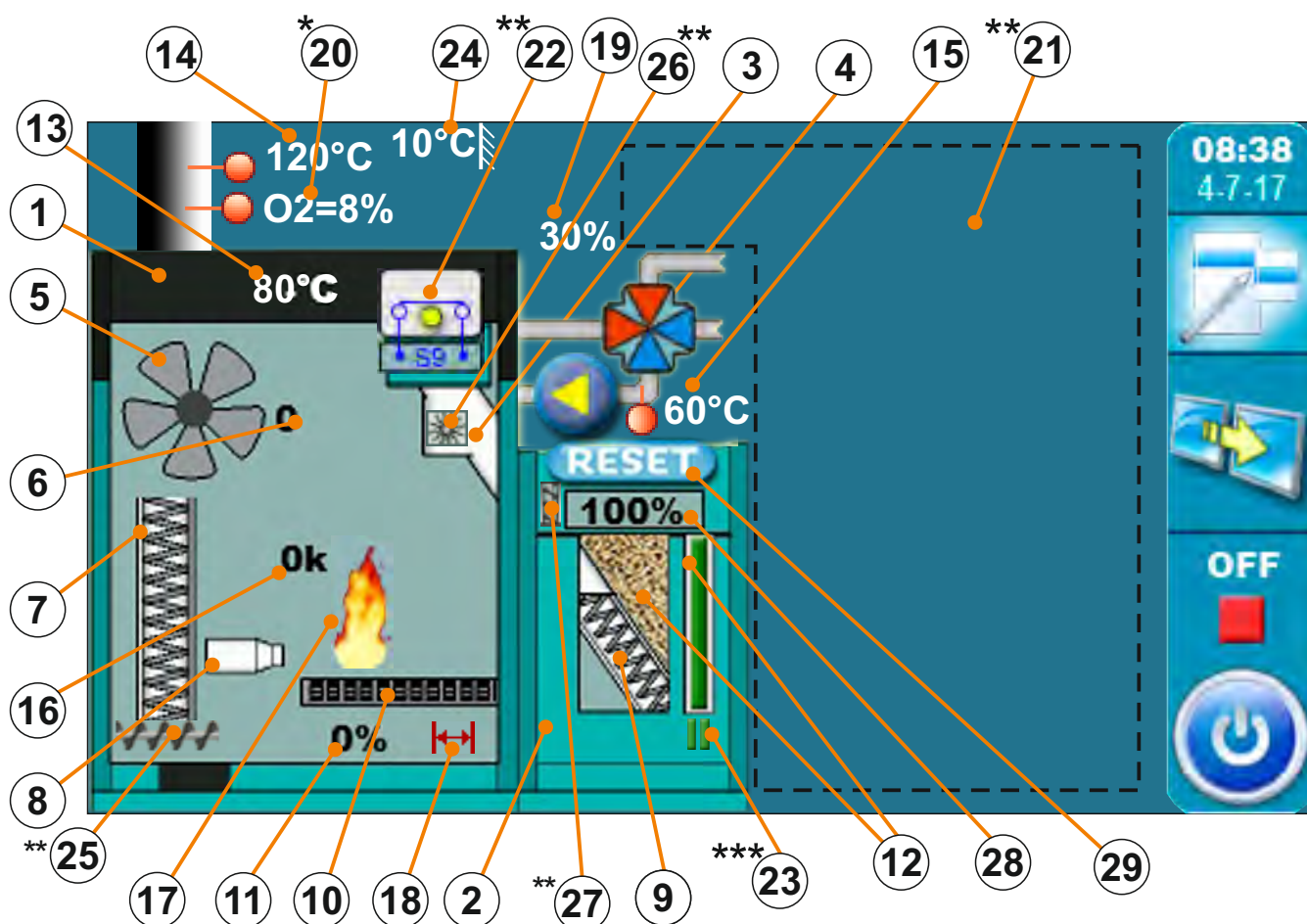

- | | |
|---|---|
| <ul style="list-style-type: none"> 1 - Boiler 2 - Pellet tank 3 - Pellet feeding screw 4 - 4-way mixing valve with motor device (when working, left/right arrow will be shown) 5 - Symbol of fan operation (when working, symbol is turning) 6 - Fan speed (rpm) 7 - Symbol of flue gas channel cleaner (when working, symbol is moving) 8 - Symbol of electric heater (when working, symbol changes color) 9 - Symbol of pellet feeding screw (when working, symbol is moving) 10 - Symbol of mechanism for grate cleaning (when working, symbol moves left/right) 11 - Current position of burner grate (0% - closed, 100% - open) 12 - Pellet level in the tank (3 levels) 13 - Boiler temperature sensor | <ul style="list-style-type: none"> 14 - Flue gas sensor 15 - Flow temperature sensor 16 - Resistance of photocell (luminous intensity of flame) 17 - Flame (symbol appears when there is the flame) 18 - Symbol of microswitch in mechanism for grate cleaning 19 - Percentage of opens of the 4-way mixing valve with motor device (0% - closed, 100% - open) *20 - The percentage of oxygen in the flue gases **21 - The symbols in this section depend on the selected configuration **22 - External control symbol (see point 13.1) ***23 - Suction system symbol (off, pause, on) 24 - Outdoor temperature sensor **25 - Ash screw (only 69/96) (additional equipment) **26 - Rotary valve (additional equipment) **27 - Screw refill (additional equipment) 28 - Percentage of fuel level (if FUEL LEVEL is ON) 29 - Fuel level percentage reset button (if FUEL LEVEL is ON) |
|---|---|

* Only on PelTec-lambda

** Displaying these symbols depends on the configuration set up by an authorized service

*** For more informations about this symbol see "Technical instructions for vacuum wood pellet feeding system".

SYMBOLS

4-way mixing valve with actuator

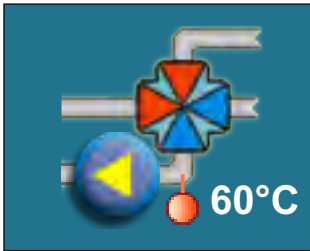

Actuator doesn't work

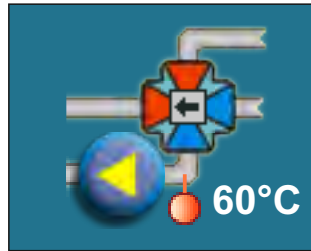

Actuator is closing the valve

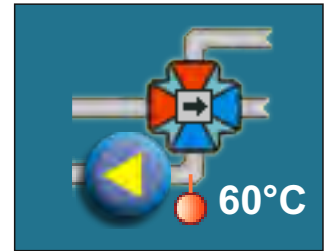

Actuator is opening the valve

Pellet feeding screw

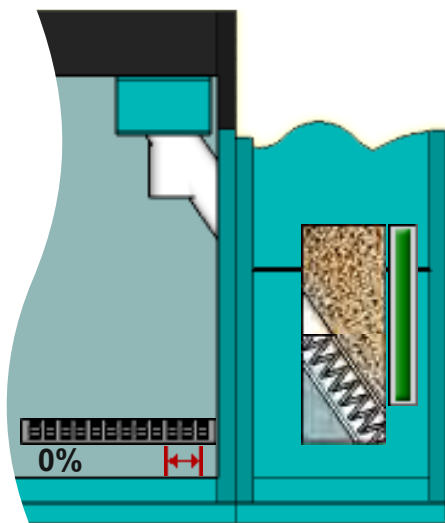

Pellet feeding screw doesn't work

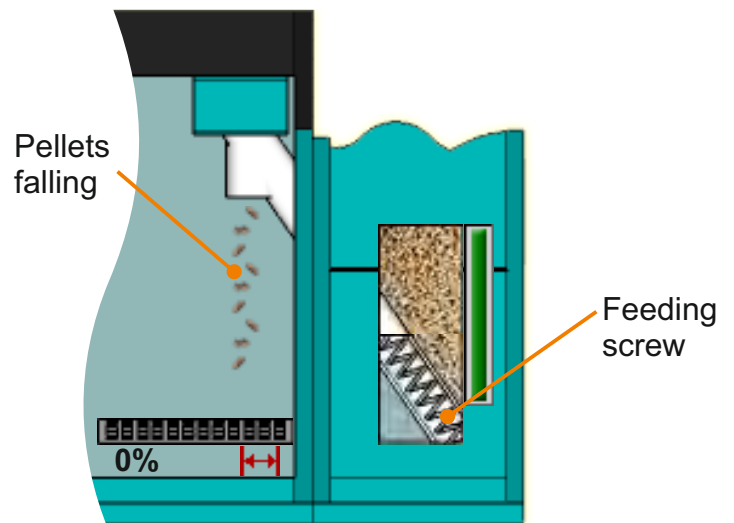

Pellet feeding screw is working (pellets are falling and screw is moving)

Flame symbol

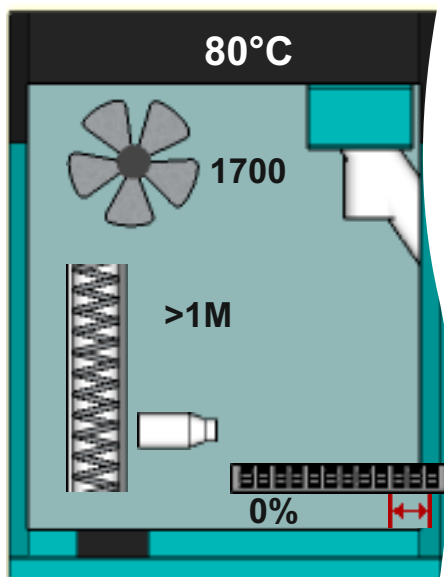

There is no flame

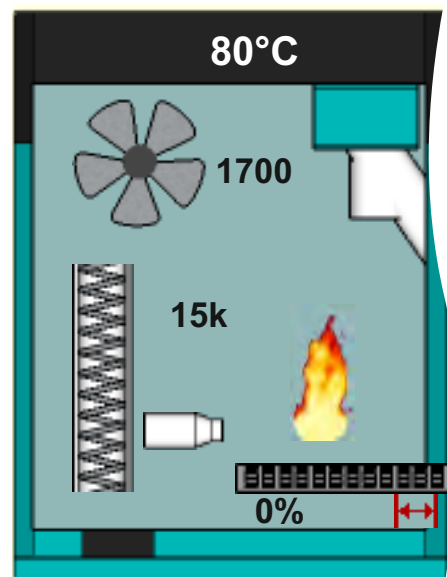

There is a flame

Symbols, Configuration symbols

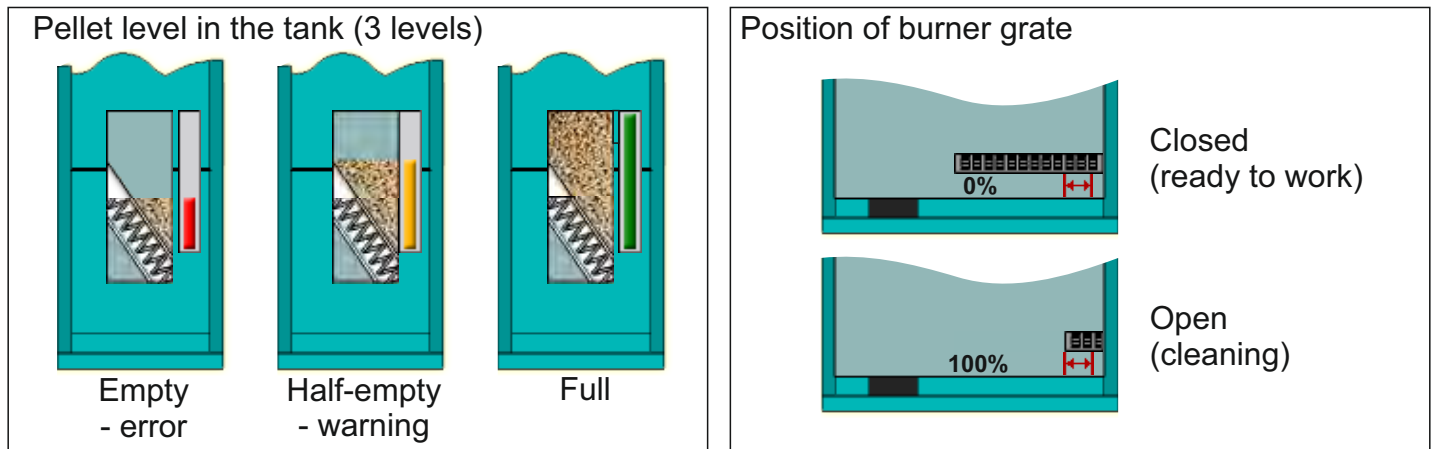

CONFIGURATION SYMBOLS

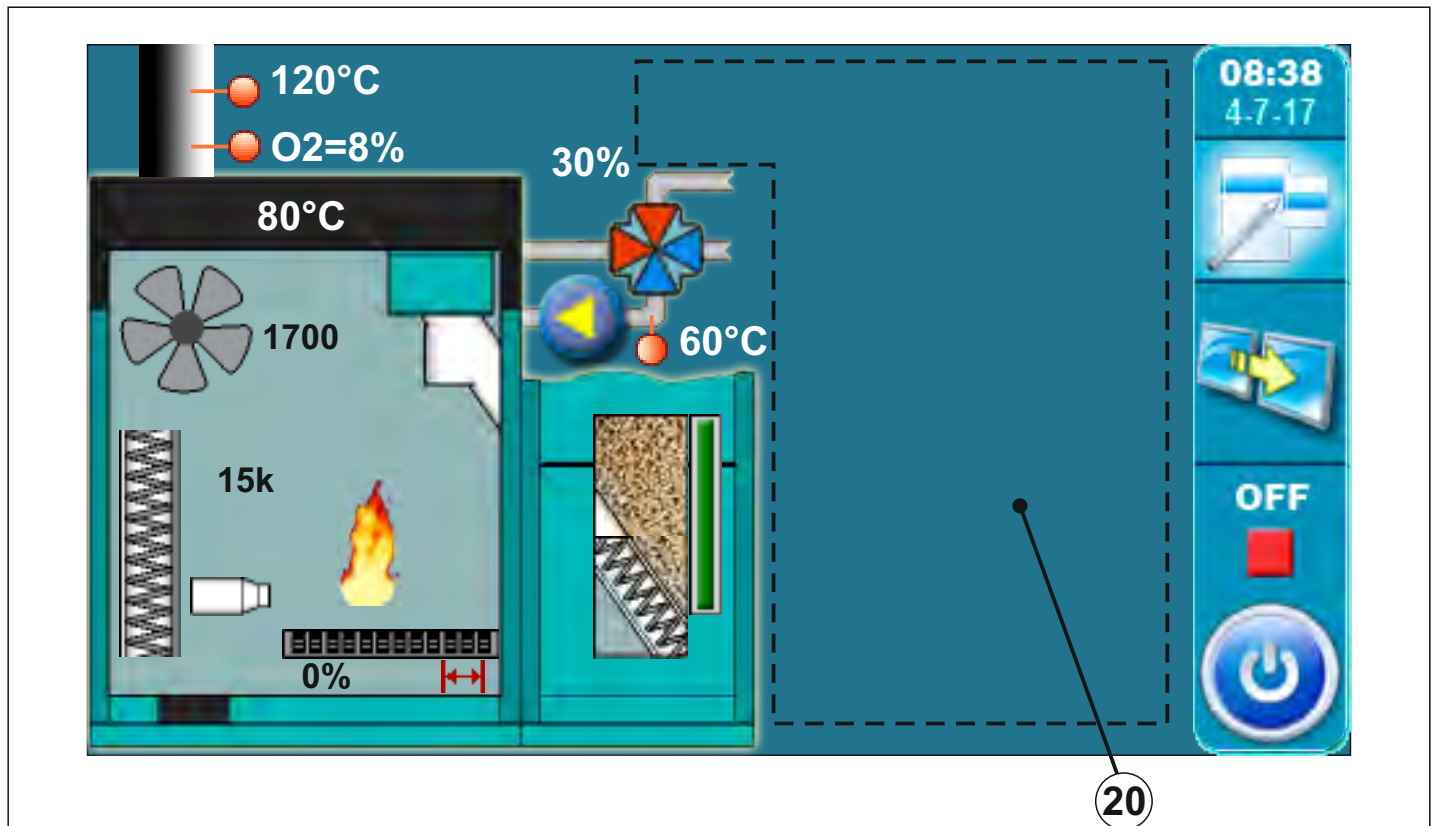

The following symbols are shown on the display configuration (page 4, mark 20 in the figure)



Pump (when pump is working symbol is rotating, otherwise idle)



The pump has a request for work (next to the pump symbol bright yellow square when the consumer given the demand for work the pump, the pump does not work if you have not met all the conditions for work, for example. low temp. in the boiler, otherwise the pump normally works)

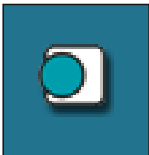

Room thermostat



Next to the room thermostat symbol bright blue circle (the room thermostat has requested for operating the pump, the pump does not work if you have not met all the conditions for its operation, for example. low temp. in the boiler, otherwise normally works)



Heating circuit



Boiler flow temperature

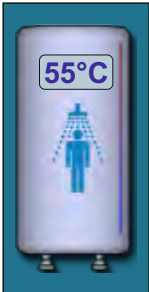

Domestic hot water tank with current temperature



Working modes

Heating + DHW mode



Only DHW mode



Only Heating mode



Automatic mode (automatic switch between working modes Heating+DHW and only DHW mode)

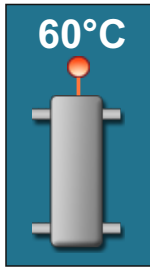

Hydraulic crossover with the current temperature

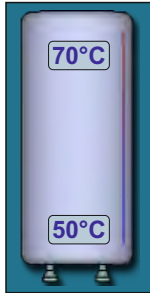

Accumulation tank with current temperature at top of the tank and at the bottom of the tank.

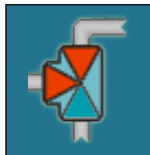

3-way diverter valve (showing the open and closed pipe)



"Chimney sweeper" option enabled



Freeze guard enabled



Freeze guard active



Boiler is started because of freeze guard option

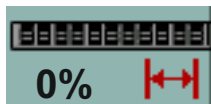

% of grate opening (0%=closed) when grate is at 0% red symbol must be shown



% of grate opening (100%=open) when grate is at 100% red symbol must be shown



symbols for opening/closing the grate (← =closing / → =opening)

1.0. MAINTENANCE



1.1. CLEANING THE BOILER

Cleaning the boiler - By pressing the button "START" (1) fan will begin work (2), an burner grate (3) will move into the open position (100%) (4), (button "START" will become a button "STOP").

This option enables you to during cleaning of combustion chamber, boiler ash does not come out of the boiler, and since the burner grate is open ash falls into the ash box. After cleaning, it is necessary to press the "STOP" to shut off the fan and burner grate move back to the closed position (0%) (4) (same thing will happen if you press the button "BACK" (5)) . After cleaning, it is necessary to empty the ashtray.

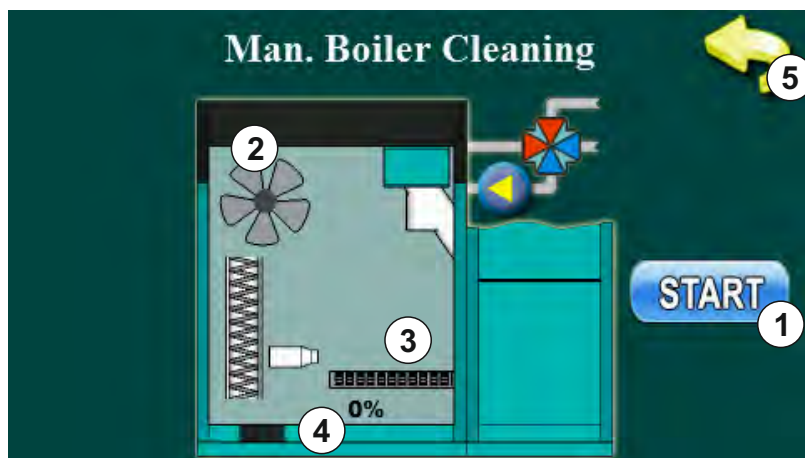

1.2. FILLING AT START

Filling at start - by pressing "START" (1) pellet feeding screw starts to operate (2) (works 25 min), and the burner grate (3) moves to the open position (100%) (4) to make pellets fall down in ashtray. After this process is complete pellet feeding screw stops working, the burner grate is returned to the closed position (0%) (4). After completion of the initial filling of pellets ashtrays need to put in pellet tank. For the duration of this process, the display shows the countdown process duration (5). Before starting this process, it is necessary to fill the pellet tank. The process may be interrupted by pressing button "STOP" or "BACK" (6).

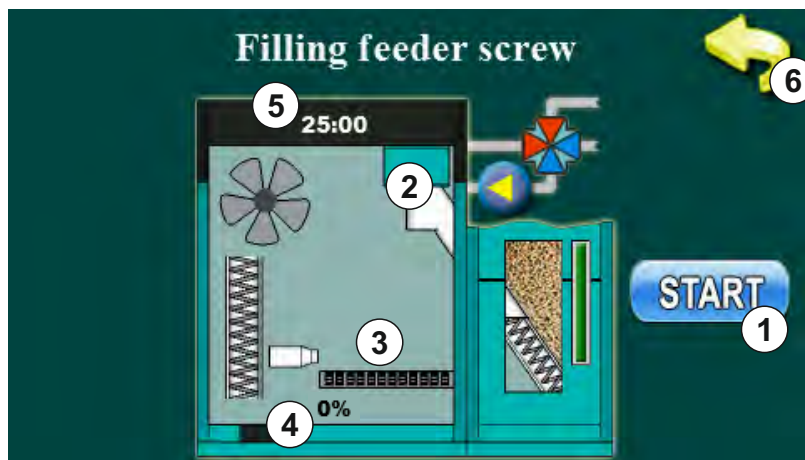

1.3. SYSTEM AIRVENT

System airvent - entering the above menu, the motor device of 4-way mixing valve opens the valve to 50% (1). By pressing "START" next to a particular pump symbol, the pump starts to work (2, 3, 4) (button "START" become button "STOP"). By pressing the button "STOP" the pump stops working. In this option is possible to work 2 or 3 pumps at the same time.

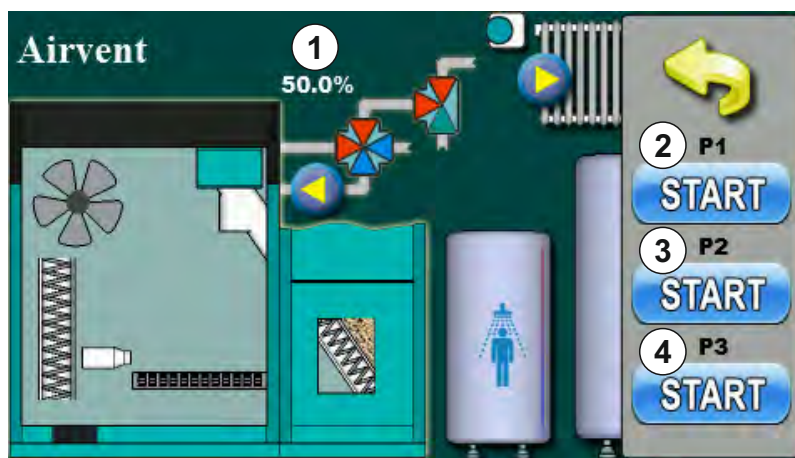

2.0. TEMPERATURE

Temperatures choice depends on the configuration of heating. Below are shown all types of installation and configuration.

CONFIGURATION 1 - DOMESTIC HOT WATER (DHW)

Scheme of configuration

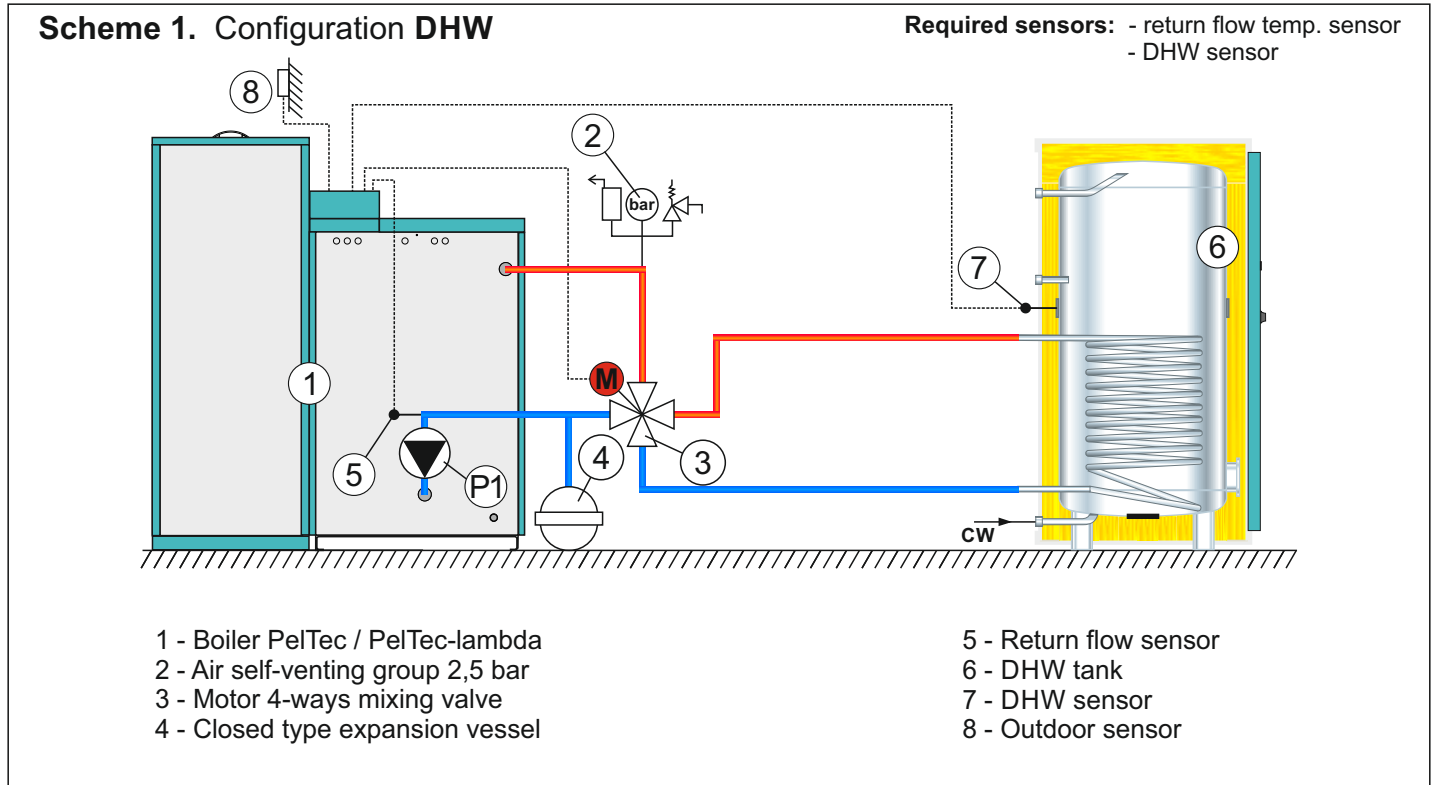

On the screen

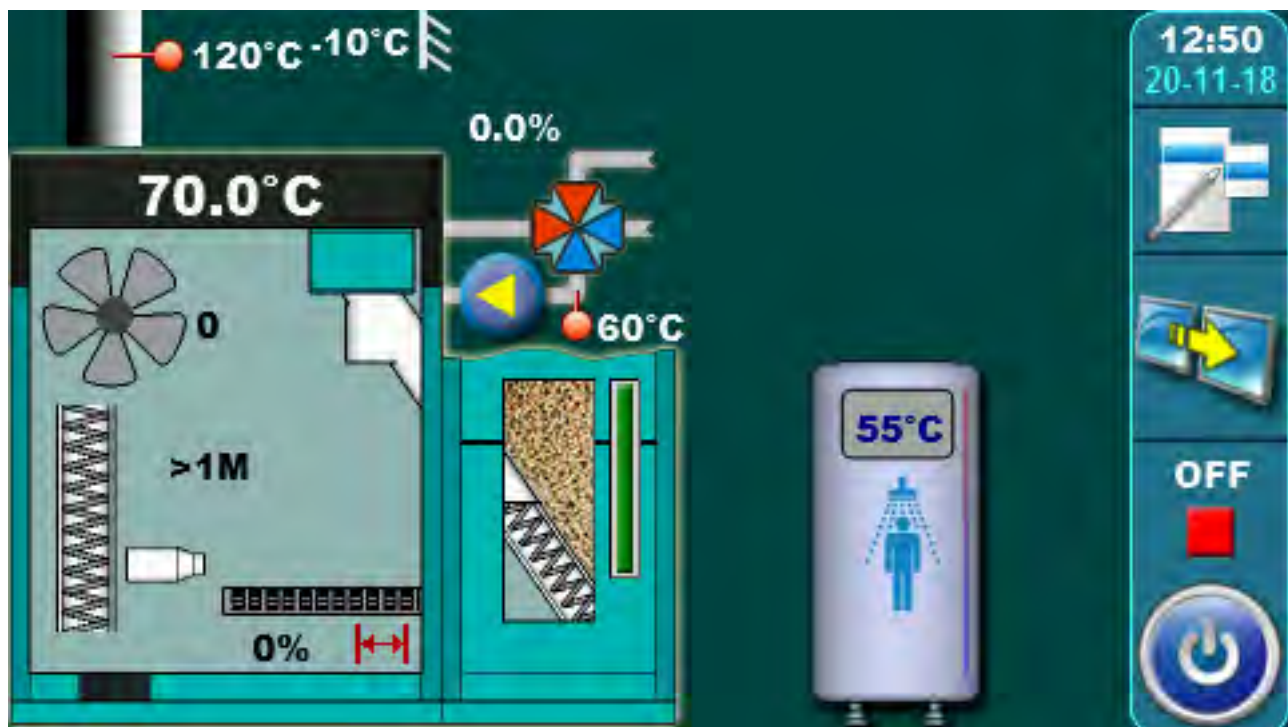

2. TEMPERATURES (CONFIGURATION DHW)

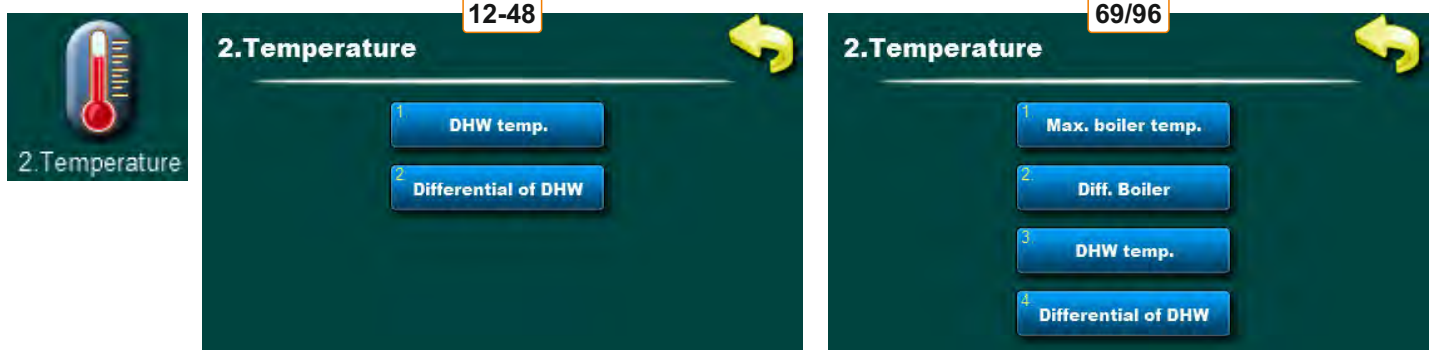

2.1 / 2.3 DHW TEMP.

Possible selection:

default: 50°C

Minimum: 40°C

Maximum: 80°C

Temperature setting options of DHW (domestic hot water).

2.2 / 2.4 DIFFERENTIAL OF DHW

Possible selection:

default: 5°C

Minimum: 4°C

Maximum: 40°C

The possibility of setting domestic hot water difference.

2.1 MAX. BOILER TEMP. (ONLY 69/96)

Possible selection:

default: 75°C

Minimum: 75°C

Maximum: 80°C

The possibility of setting maximum boiler temperature.

2.2 DIFF. BOILER (ONLY 69/96)

Possible selection:

default: 8°C

The view of boiler difference setting (**not possible to change**).

CONFIGURATION 2 - DIRECT HEATING CIRCUIT (DHC)

Scheme of configuration

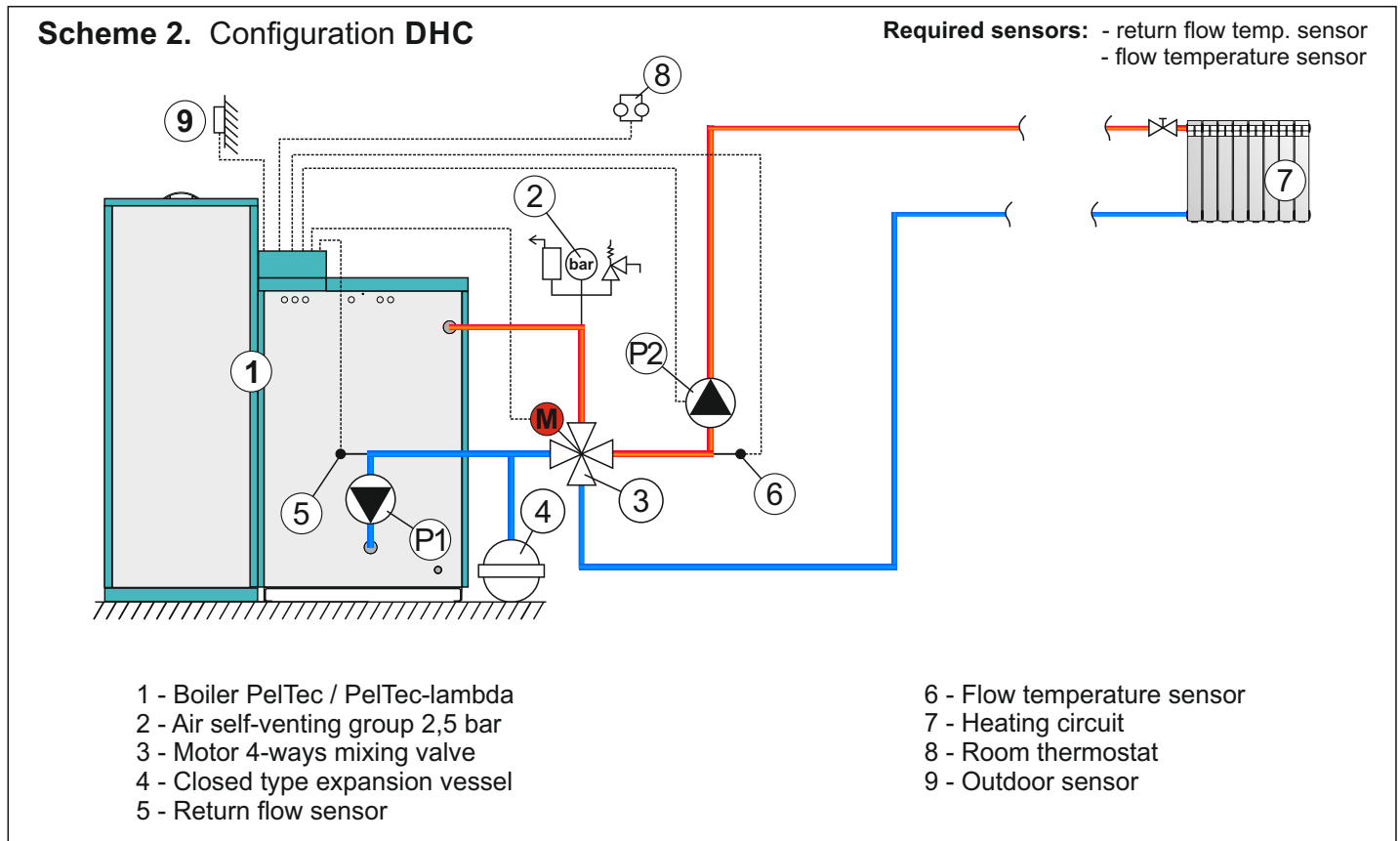

On the screen

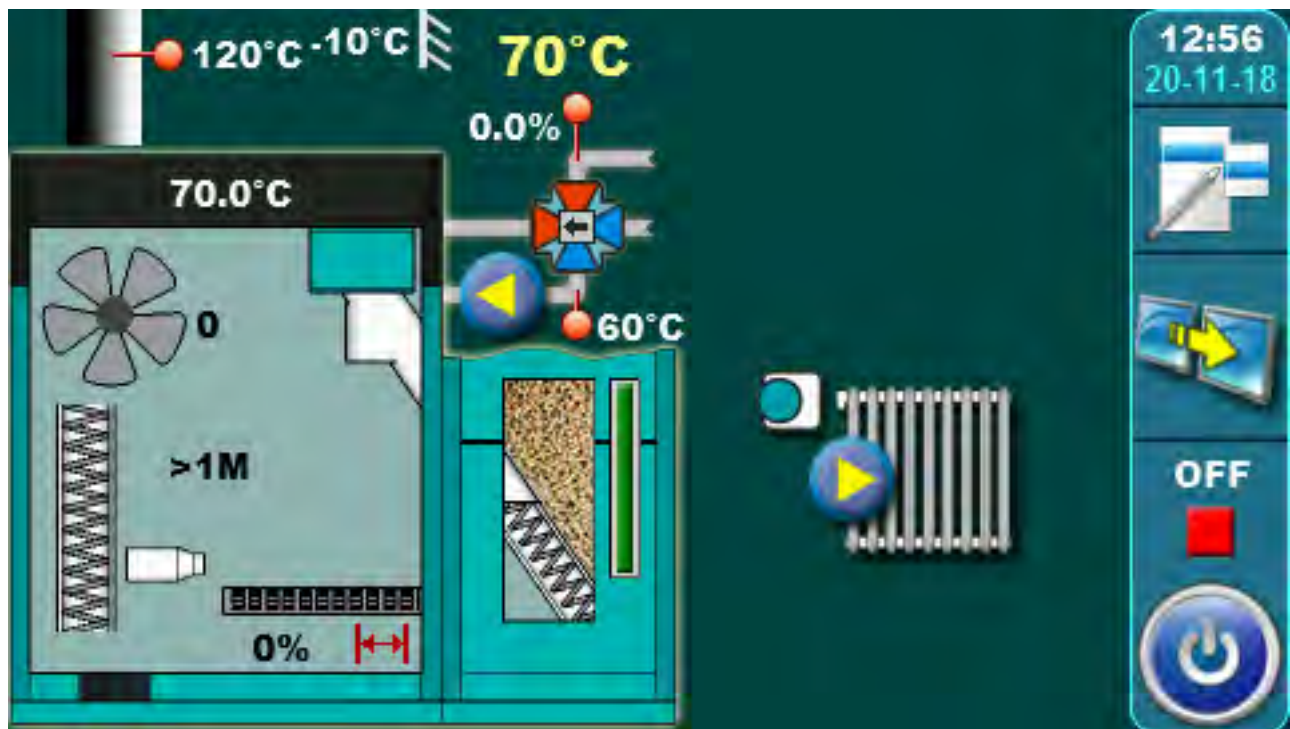

2. TEMPERATURE (CONFIGURATION DHC)

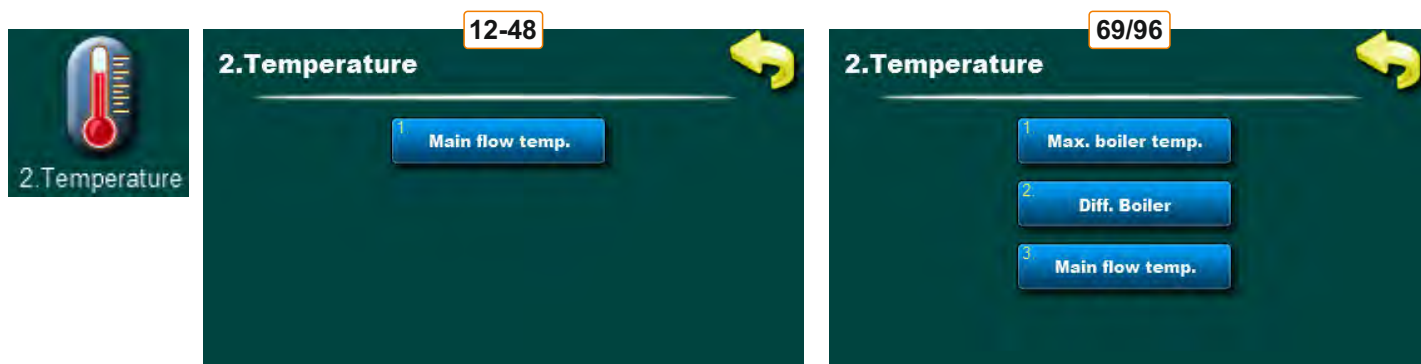

2.1 / 2.3 MAIN FLOW TEMP.

Possible selection:

default: 60°C

Minimum: 30°C

Maximum: 90°C

The possibility of setting main flow temperature.

2.1 MAX. BOILER TEMP. (ONLY 69/96)

Possible selection:

default: 75°C

Minimum: 75°C

Maximum: 80°C

The possibility of setting maximum boiler temperature.

2.2 DIFF. BOILER (ONLY 69/96)

Possible selection:

default: 8°C

The view of boiler difference setting (**not possible to change**).

CONFIGURATION 3 - DHC || DHW

Scheme of configuration

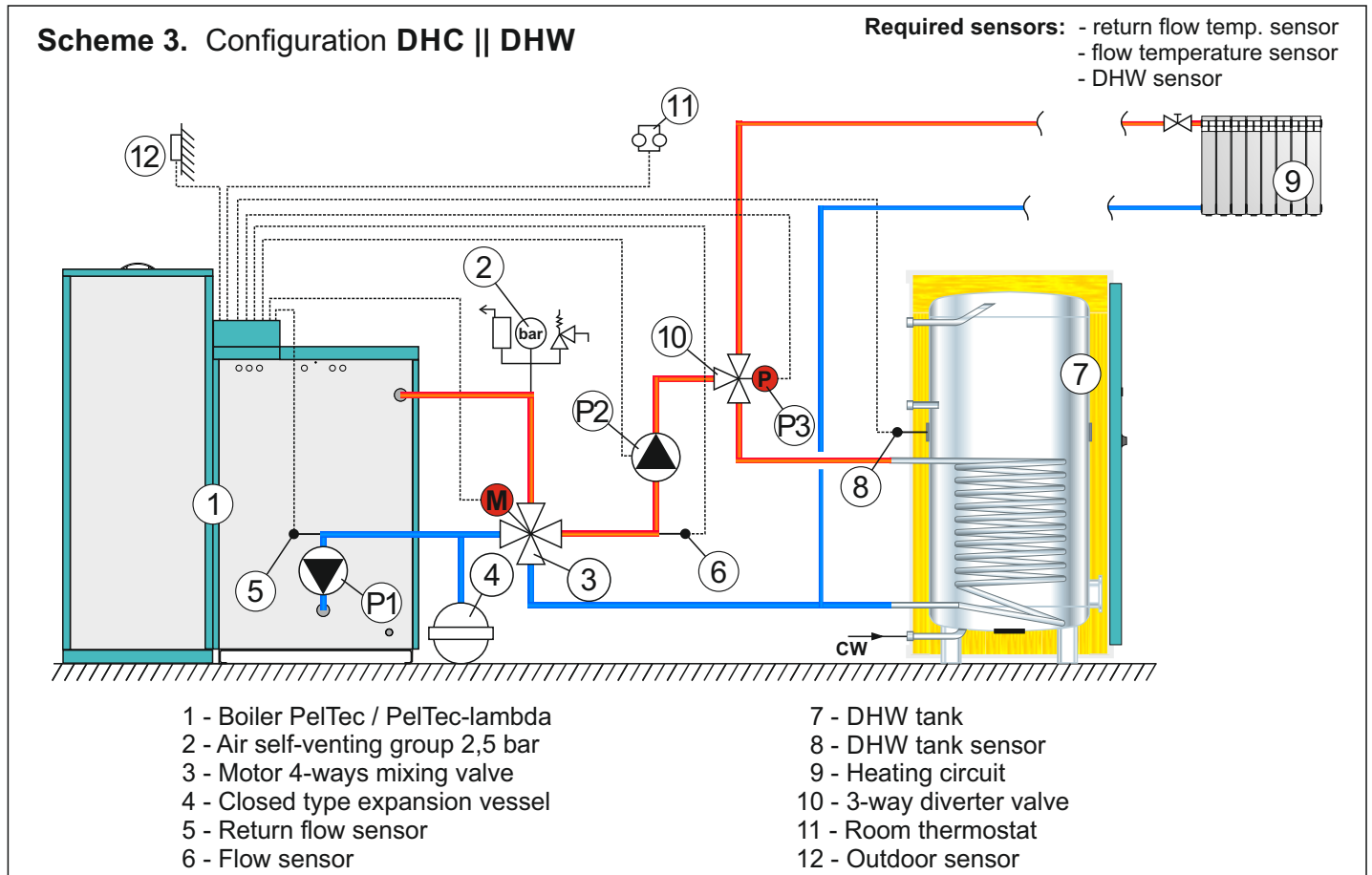

On the screen

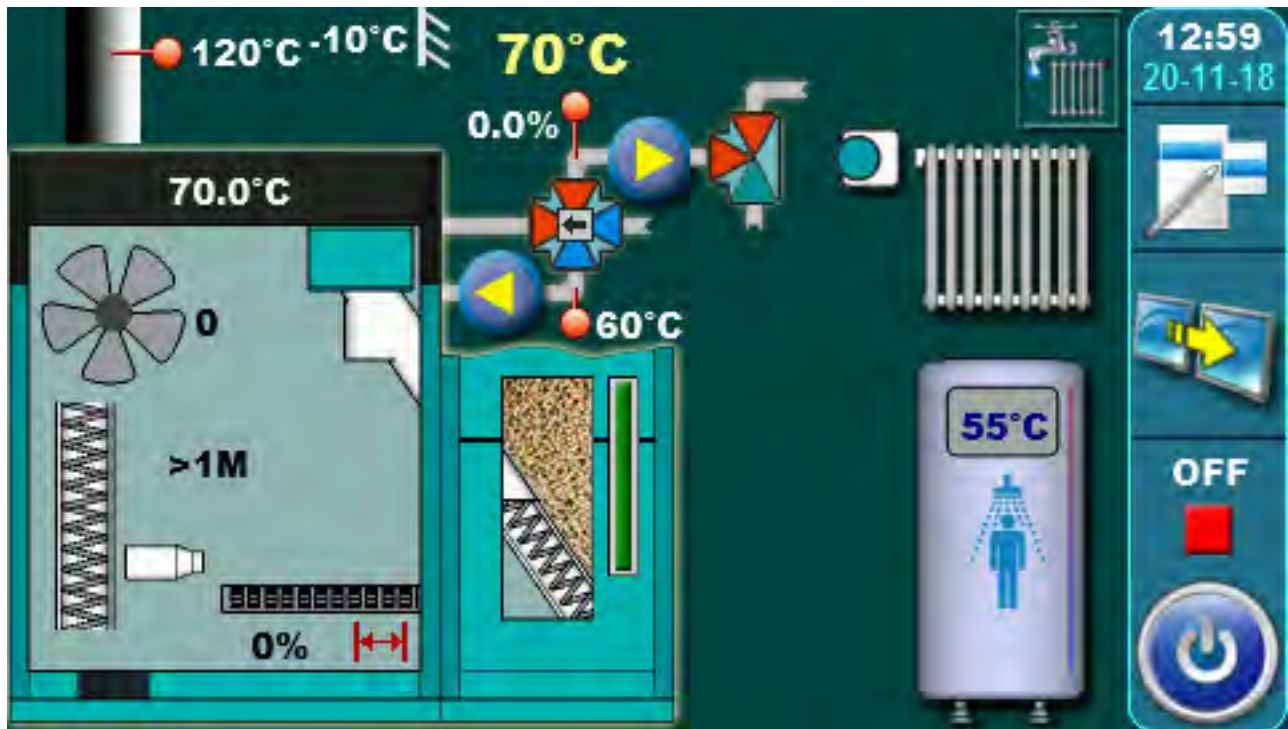

2. TEMPERATURE (CONFIGURATION DHW || DHC)

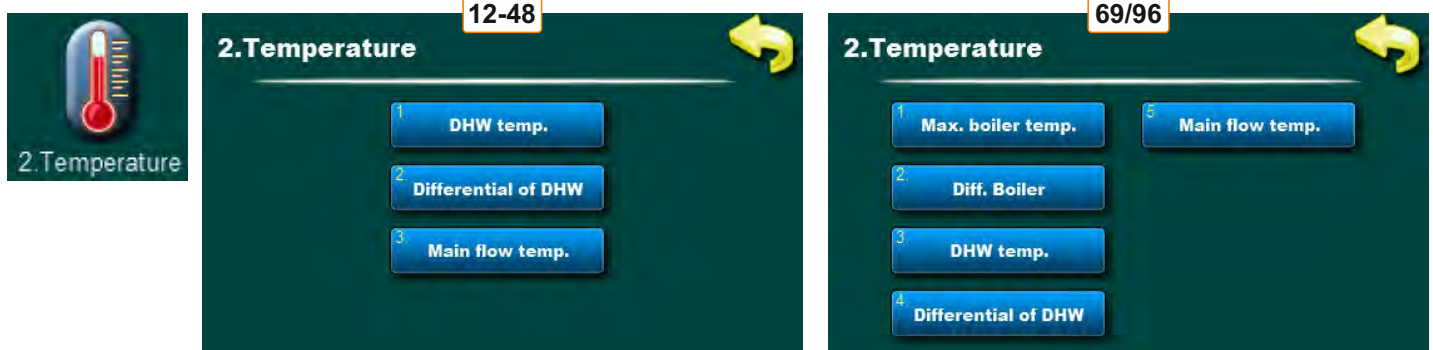

2.1 / 2.3 DHW TEMP.

Possible selection:

default: 50°C

Minimum: 40°C

Maximum: 80°C

Temperature setting options of DHW (domestic hot water).

2.2 / 2.4 DIFFERENTIAL OF DHW

Possible selection:

default: 5°C

Minimum: 4°C

Maximum: 40°C

The possibility of setting differential of DHW.

2.3 / 2.5 MAIN FLOW TEMP.

Possible selection:

default: 60°C

Minimum: 30°C

Maximum: 90°C

The possibility of setting main flow temperature

2.1 MAX. BOILER TEMP. (ONLY 69/96)

Possible selection:

default: 75°C

Minimum: 75°C

Maximum: 80°C

The possibility of setting maximum boiler temperature.

2.2 DIFF. BOILER (ONLY 69/96)

Possible selection:

default: 8°C

The view of boiler difference setting (**not possible to change**).

CONFIGURATION 4 - ACCUMULATION TANK

Scheme of configuration

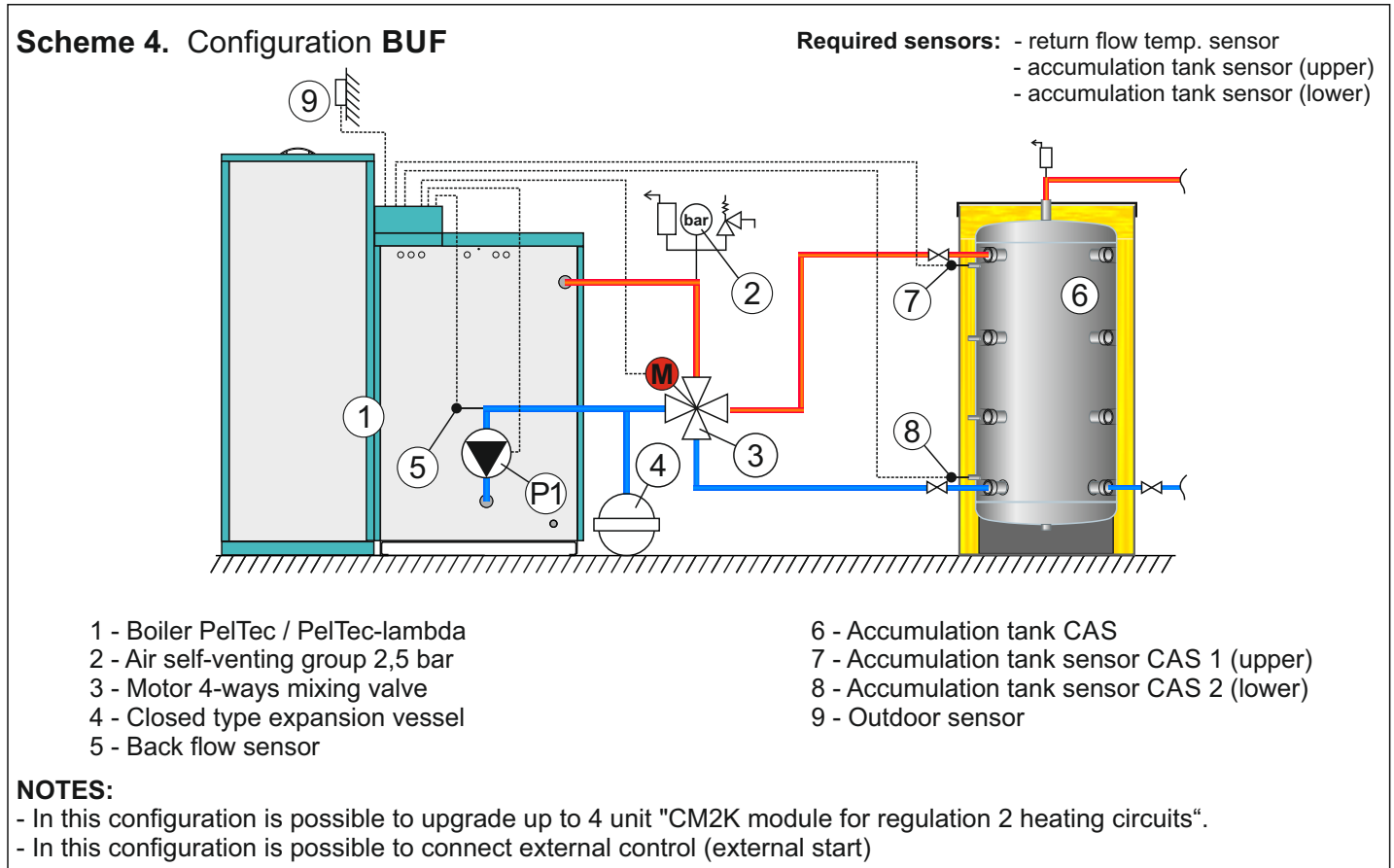

On the screen

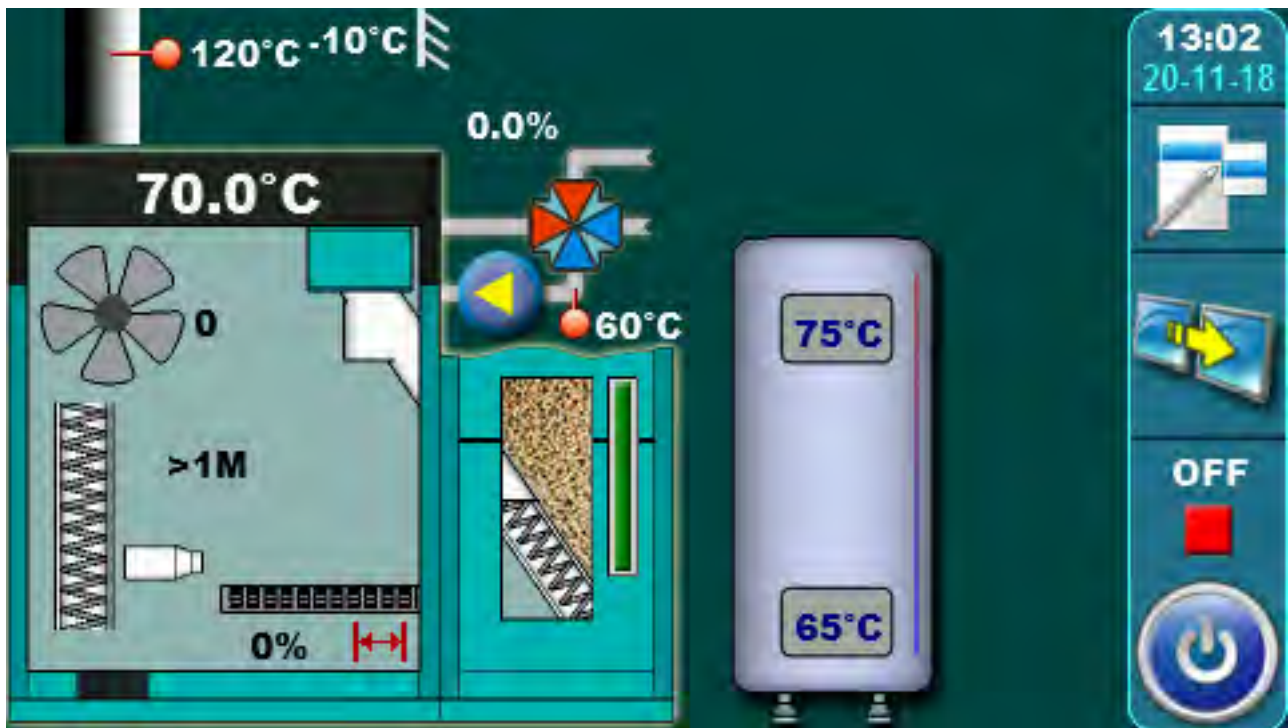

2. TEMPERATURE (CONFIGURATION BUF)

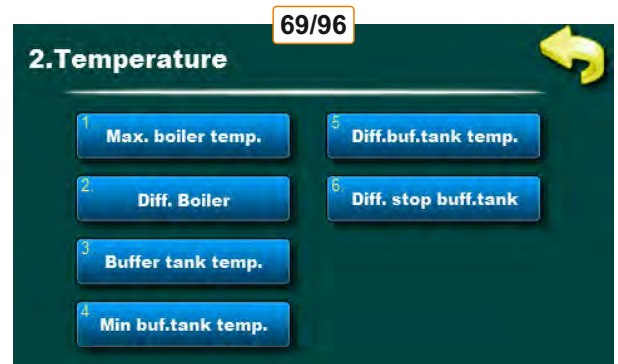

2.1 / 2.3 BUFFER TANK TEMP.

Possible selection:

default: 80°C

Minimum: 40°C

Maximum: 85°C

The possibility of setting the desired temperature of the accumulation tank.

2.2 / 2.4 MIN. BUF. TANK TEMP.

Possible selection:

default: 20°C

Minimum: 5°C

Maximum: 64°C

The possibility of setting the minimum temperature of the accumulation tank. When minimum temperature of accumulation tank (upper sensor) is reached, all heat pumps connected to the boiler control will be shut down. The minimum accumulation tank temperature does not affect the operation of the DHW pump.

2.3 / 2.5 DIFF. BUF. TANK TEMP.

Possible selection:

default: 10°C

Minimum: 5°C

Maximum: 30°C

The possibility of setting the accumulation tank start difference.

2.4 / 2.6 DIFF. STOP BUF. TANK

Possible selection:

default: 5°C

Minimum: 3°C

Maximum: 30°C

The possibility of setting the accumulation tank stop difference.

2.1 MAX. BOILER TEMP. (ONLY 69/96)

Possible selection:

default: 85°C

Minimum: 80°C

Maximum: 90°C

The possibility of setting maximum boiler temperature.

2.2 DIFF. BOILER (ONLY 69/96)

Possible selection:

default: 8°C

The view of boiler difference setting (**not possible to change**).

Description of work:

The regulation reads on the upper sensor accumulation tank temperature, minimum accumulation tank temperature and accumulation tank difference. At the bottom sensor, regulation reads the accumulation tank shutdown difference that can be set in the installation menu (under PIN). When the boiler is switched on, it works until the temperature on the lower sensor (T accumulation tank - T accumulation tank shutdown difference) is reached. The boiler will turn ON again when accumulation tank upper temperature (upper sensor) reach the (T accumulation tank - T accumulation tank difference).

CONFIGURATION 5 - DHW||BUF

Scheme of configuration

Scheme 5. Configuration DHW || BUF

Required sensors: - return flow temp. sensor
 - DHW tank sensor
 - accumulation tank sensor (upper)
 - accumulation tank sensor (lower)

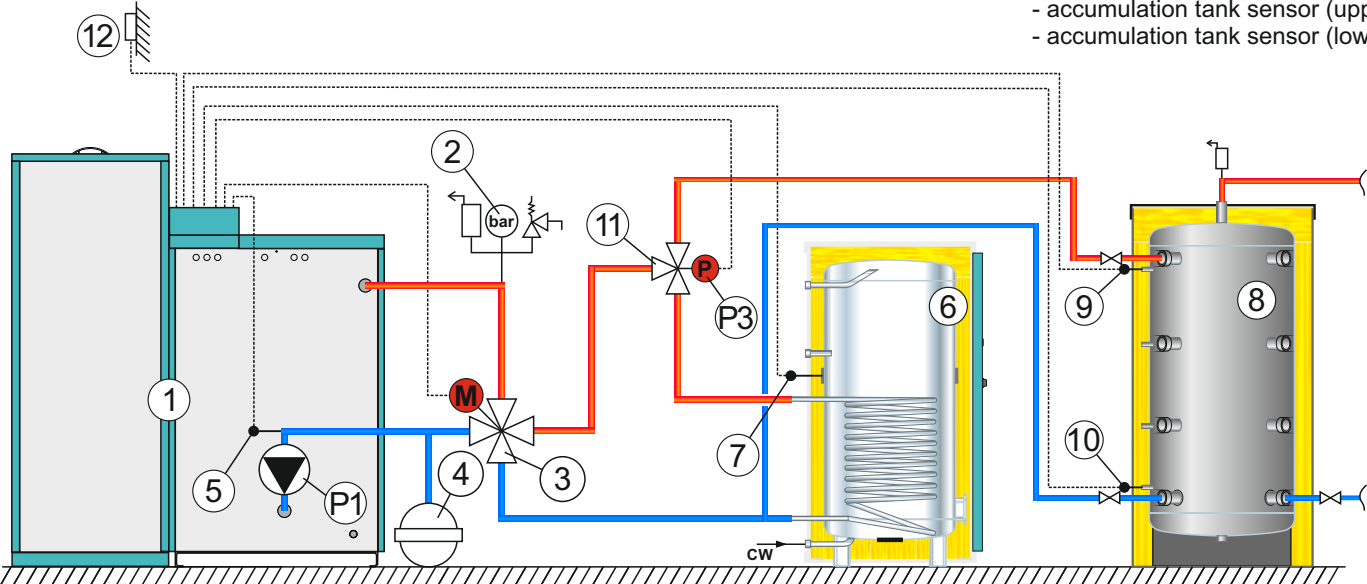

- 1 - Boiler PelTec / PelTec-lambda
- 2 - Air self-venting group 2,5 bar
- 3 - Motor 4-ways mixing valve
- 4 - Closed type expansion vessel
- 5 - Return flow sensor
- 6 - DHV tank

- 7 - DHW tank sensor
- 8 - Accumulation tank CAS
- 9 - Accumulation tank sensor CAS 1 (upper)
- 10 - Accumulation tank sensor CAS 2 (lower)
- 11 - 3-way diverter valve
- 12 - Outdoor sensor

NOTE:

In this configuration is possible to upgrade up to 4 unit "CM2K module for regulation 2 heating circuits".

On the screen

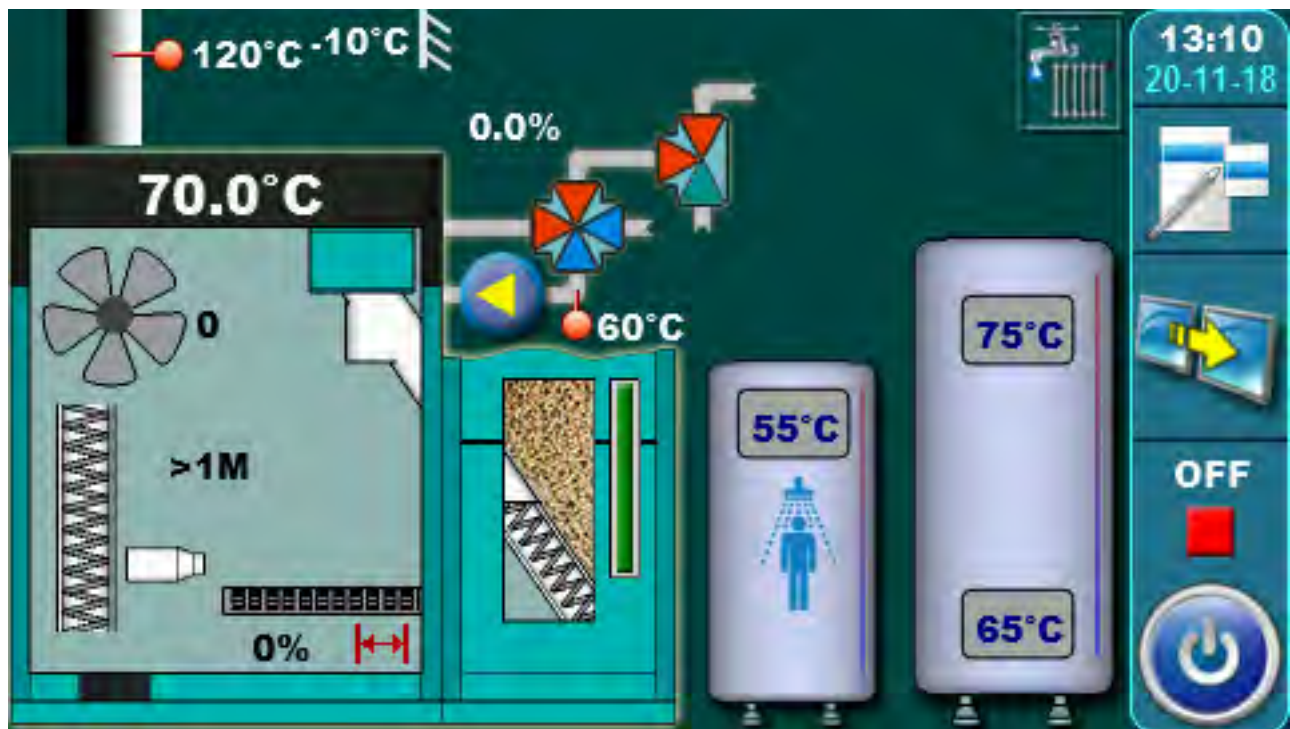

2. TEMPERATURE (CONFIGURATION DHW || BUF)



2.1 / 2.4 BUFFER TANK TEMP.

Possible selection:

default: 80°C

Minimum: 40°C

Maximum: 85°C

The possibility of setting the desired temperature of the accumulation tank.

2.2 / 2.5 MIN. BUF. TANK TEMP.

Possible selection:

default: 20°C

Minimum: 5°C

Maximum: 64°C

The possibility of setting the minimum temperature of the accumulation tank.

2.3 / 2.6 DIF. BUF. TANK TEMP.

Possible selection:

default: 10°C

Minimum: 5°C

Maximum: 30°C

The possibility of setting the accumulation tank start difference.

2.4 / 2.7 DIF. STOP BUFF. TANK TEMP.

Possible selection:

default: 10°C

Minimum: 5°C

Maximum: 30°C

The possibility of setting the accumulation tank stop difference.

2.5 DHW TEMP.

Possible selection:

default: 50°C

Minimum: 40°C

Maximum: 80°C

Temperature setting options of DHW (domestic hot water).

2.6 DIFFERENTIAL OF DHW

Possible selection:

default: 5°C

Minimum: 4°C

Maximum: 40°C

The possibility of setting domestic hot water difference.

2.1 MAX. BOILER TEMP. DHW (ONLY 69/96)

Possible selection:

default: 75°C

Minimum: 75°C

Maximum: 80°C

The possibility of setting maximum boiler temperature for DHW heating.

2.2 MAX. BOILER TEMP. PUF. (ONLY 69/96)

Possible selection:

default: 85°C

Minimum: 80°C

Maximum: 90°C

The possibility of setting maximum boiler temperature for Accumulation tank heating.

2.3 DIFF. BOILER (ONLY 69/96)

Possible selection:

default: 8°C

The view of boiler difference setting **(not possible to change)**.

CONFIGURATION 6 - BUF--IHC

Scheme of configuration

Scheme 6. Configuration BUF -- IHC

Required sensors: - return flow temp. sensor
 - accumulation tank sensor (upper)
 - accumulation tank sensor (lower)

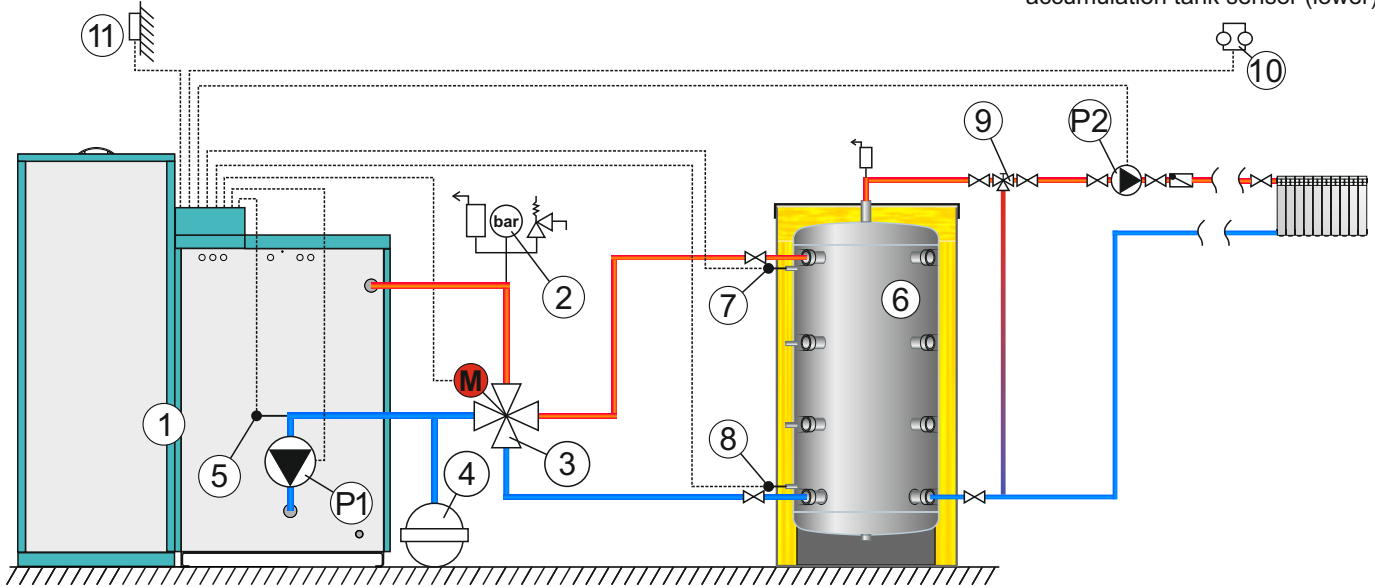

- | | |
|------------------------------------|--|
| 1 - Boiler PelTec / PelTec-lambda | 7 - Accumulation tank sensor CAS 1 (upper) |
| 2 - Air self-venting group 2,5 bar | 8 - Accumulation tank sensor CAS 2 (lower) |
| 3 - Motor 4-ways mixing valve | 9 - 3-way manual mixing valve |
| 4 - Closed type expansion vessel | 10 - Room thermostat |
| 5 - Return flow sensor | 11 - Outdoor sensor |
| 6 - Accumulation tank CAS | |

NOTES:

- In this configuration is possible to upgrade up to 4 unit "CM2K module for regulation 2 heating circuits".
- In this configuration is possible to connect external control (external start)

On the screen

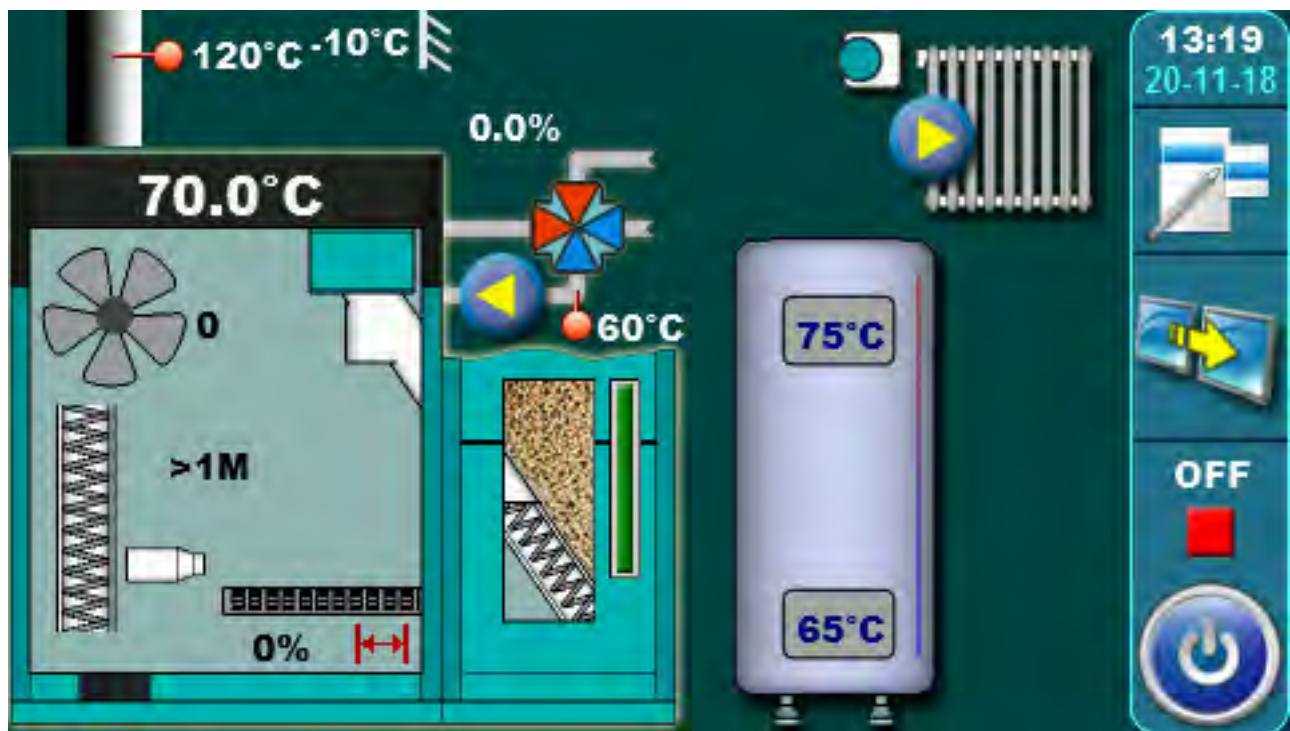

2. TEMPERATURE (CONFIGURATION BUF--IHC)

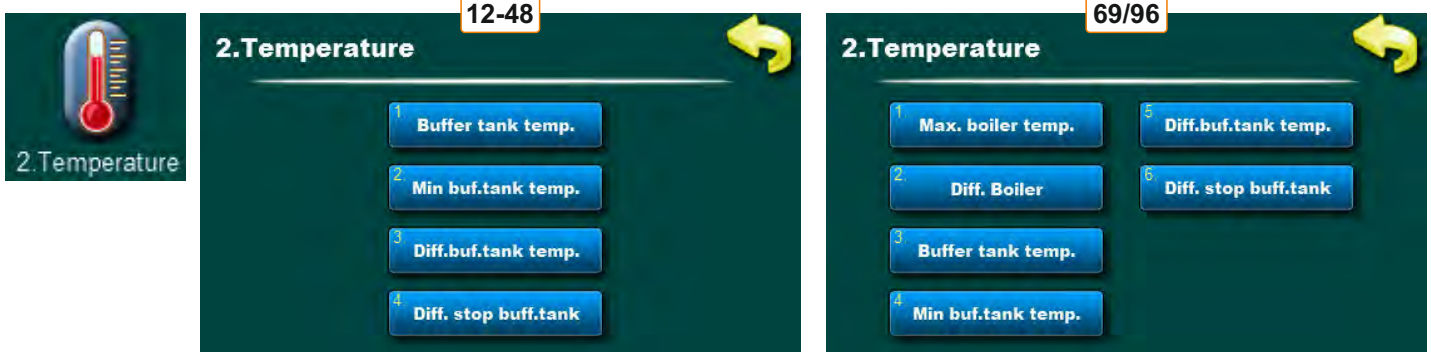

2.1 / 2.3 BUFFER TANK TEMP.

Possible selection:

default: 80°C

Minimum: 40°C

Maximum: 85°C

The possibility of setting the desired temperature of the accumulation tank.

2.2 / 2.4 MIN. BUF. TANK TEMP.

Possible selection:

default: 20°C

Minimum: 5°C

Maximum: 64°C

The possibility of setting the minimum temperature of the accumulation tank.

2.3 / 2.5 DIFF. BUF. TANK TEMP.

Possible selection:

default: 10°C

Minimum: 5°C

Maximum: 30°C

The possibility of setting the accumulation tank start difference.

2.4 / 2.6 DIFF. STOP BUFF. TANK

Possible selection:

default: 10°C

Minimum: 5°C

Maximum: 30°C

The possibility of setting the accumulation tank stop difference.

2.1 MAX. BOILER TEMP. (ONLY 69/96)

Possible selection:

default: 75°C

Minimum: 75°C

Maximum: 80°C

The possibility of setting maximum boiler temperature.

2.2 DIFF. BOILER (ONLY 69/96)

Possible selection:

default: 8°C

The view of boiler difference setting (**not possible to change**).

CONFIGURATION 7 - DHW || BUF--IHC

Scheme of configuration

Scheme 7. Configuration DHW || BUF -- IHC

Required sensors: - return flow temp. sensor
 - DHW tank sensor
 - accumulation tank sensor (upper)
 - accumulation tank sensor (lower)

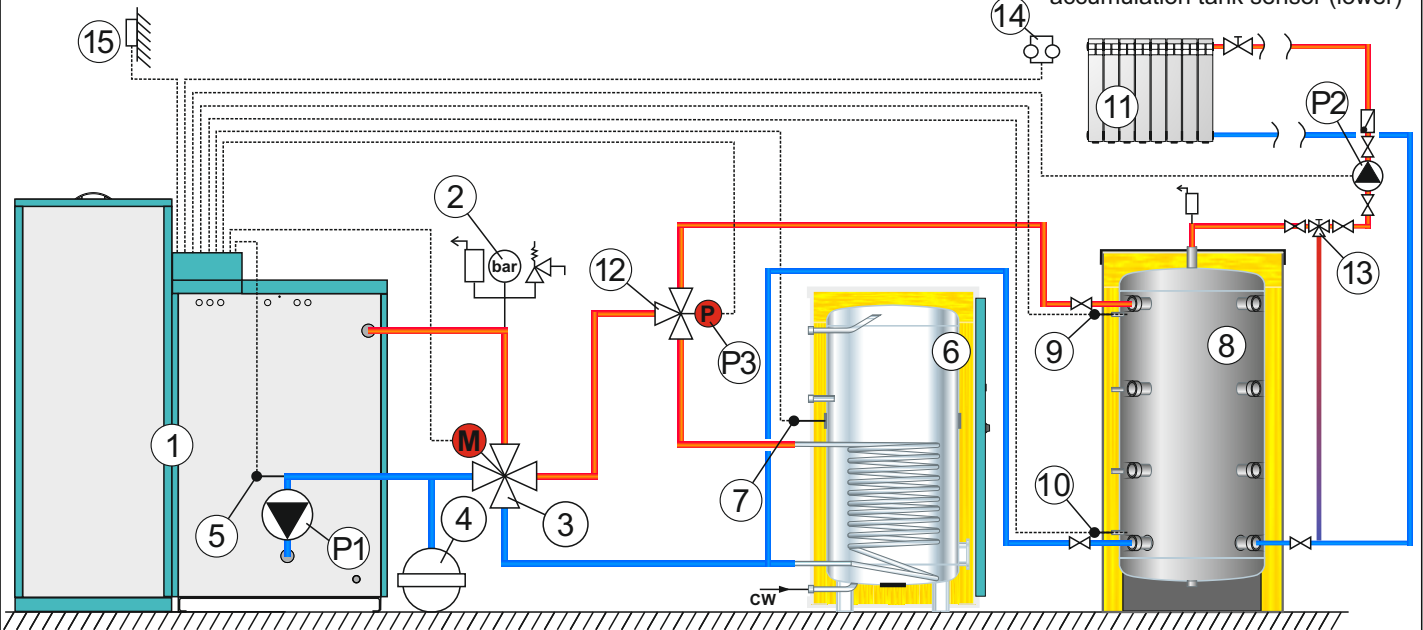

- | | |
|------------------------------------|---|
| 1 - Boiler PelTec / PelTec-lambda | 9 - Accumulation tank sensor CAS 1 (upper) |
| 2 - Air self-venting group 2,5 bar | 10 - Accumulation tank sensor CAS 2 (lower) |
| 3 - Motor 4-ways mixing valve | 11 - Heating circuit |
| 4 - Closed type expansion vessel | 12 - 3-way diverter valve |
| 5 - Return flow sensor | 13 - 3-way manual mixing valve |
| 6 - DHV tank | 14 - Room thermostat |
| 7 - DHV tank sensor | 15 - Outdoor sensor |
| 8 - Accumulation tank CAS | |

NOTE:

In this configuration is possible to upgrade up to 4 unit "CM2K module for regulation 2 heating circuits".

On the screen

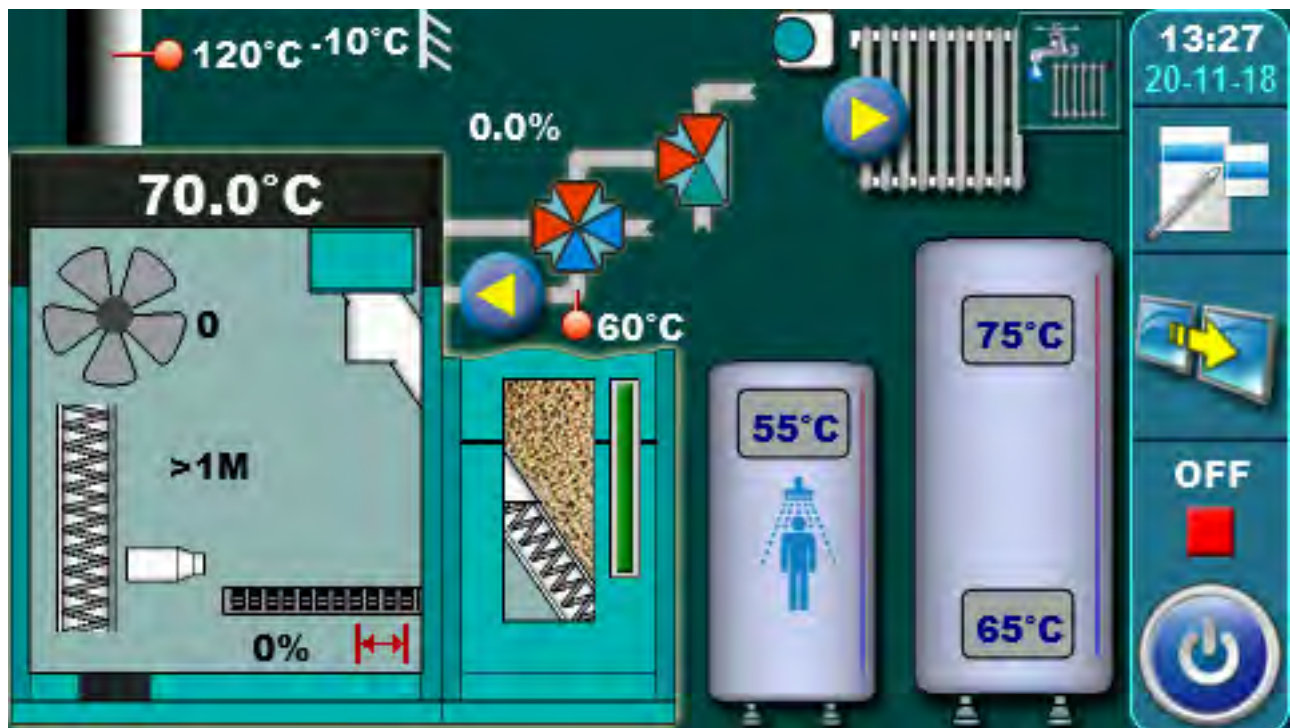

2. TEMPERATURE (CONFIGURATION DHW || BUF--IHC)

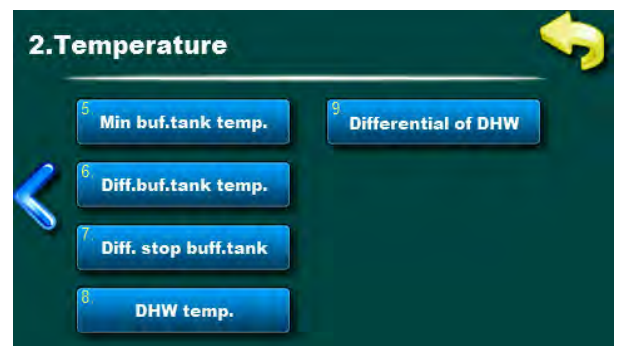
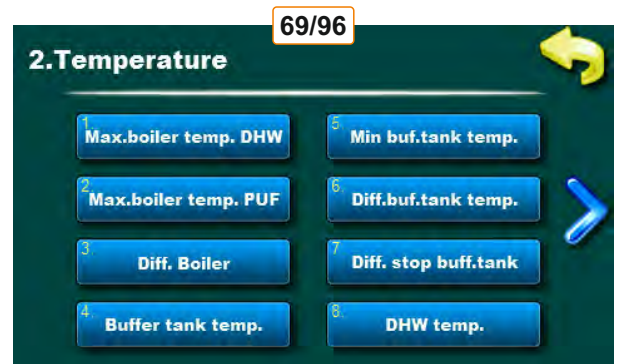
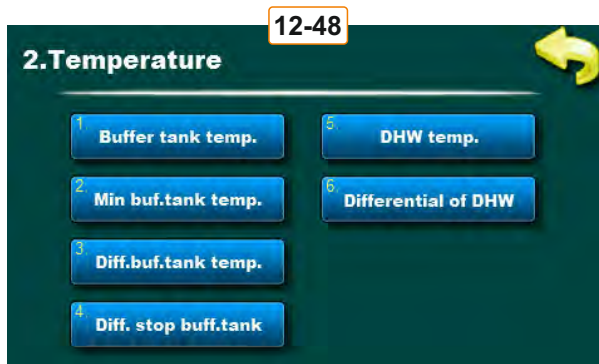

2.1 / 2.4 BUFFER TANK TEMP.

Possible selection:

default: 80°C

Minimum: 40°C

Maximum: 85°C

The possibility of setting the desired temperature of the accumulation tank.

2.2 / 2.5 MIN. BUF. TANK TEMP.

Possible selection:

default: 20°C

Minimum: 5°C

Maximum: 64°C

The possibility of setting the minimum temperature of the accumulation tank.

2.3 / 2.6 DIFF. BUF. TANK TEMP.

Possible selection:

default: 10°C

Minimum: 5°C

Maximum: 30°C

The possibility of setting the accumulation tank start difference.

2.4 / 2.7 DIF. STOP BUFF. TANK

Possible selection:

default: 5°C

Minimum: 3°C

Maximum: 30°C

The possibility of setting the accumulation tank stop difference.

2.5 / 2.8 DHW TEMP.

Possible selection:

default: 50°C

Minimum: 40°C

Maximum: 80°C

Temperature setting options of DHW (domestic hot water).

2.6 / 2.9 DIFFERENTIAL OF DHW

Possible selection:

default: 5°C

Minimum: 4°C

Maximum: 40°C

The possibility of setting domestic hot water difference.

2.1 MAX. BOILER TEMP. DHW (ONLY 69/96)

Possible selection:

default: 75°C

Minimum: 75°C

Maximum: 80°C

The possibility of setting maximum boiler temperature for DHW.

2.2 MAX. BOILER TEMP. PUF (ONLY 69/96)

Possible selection:

default: 85°C

Minimum: 80°C

Maximum: 90°C

The possibility of setting maximum boiler temperature for accumulation tank.

2.3 DIFF. BOILER (ONLY 69/96)

Possible selection:

default: 8°C

The view of boiler difference setting (**not possible to change**).

CONFIGURATION 8 - BUF-- DHW

Scheme of configuration

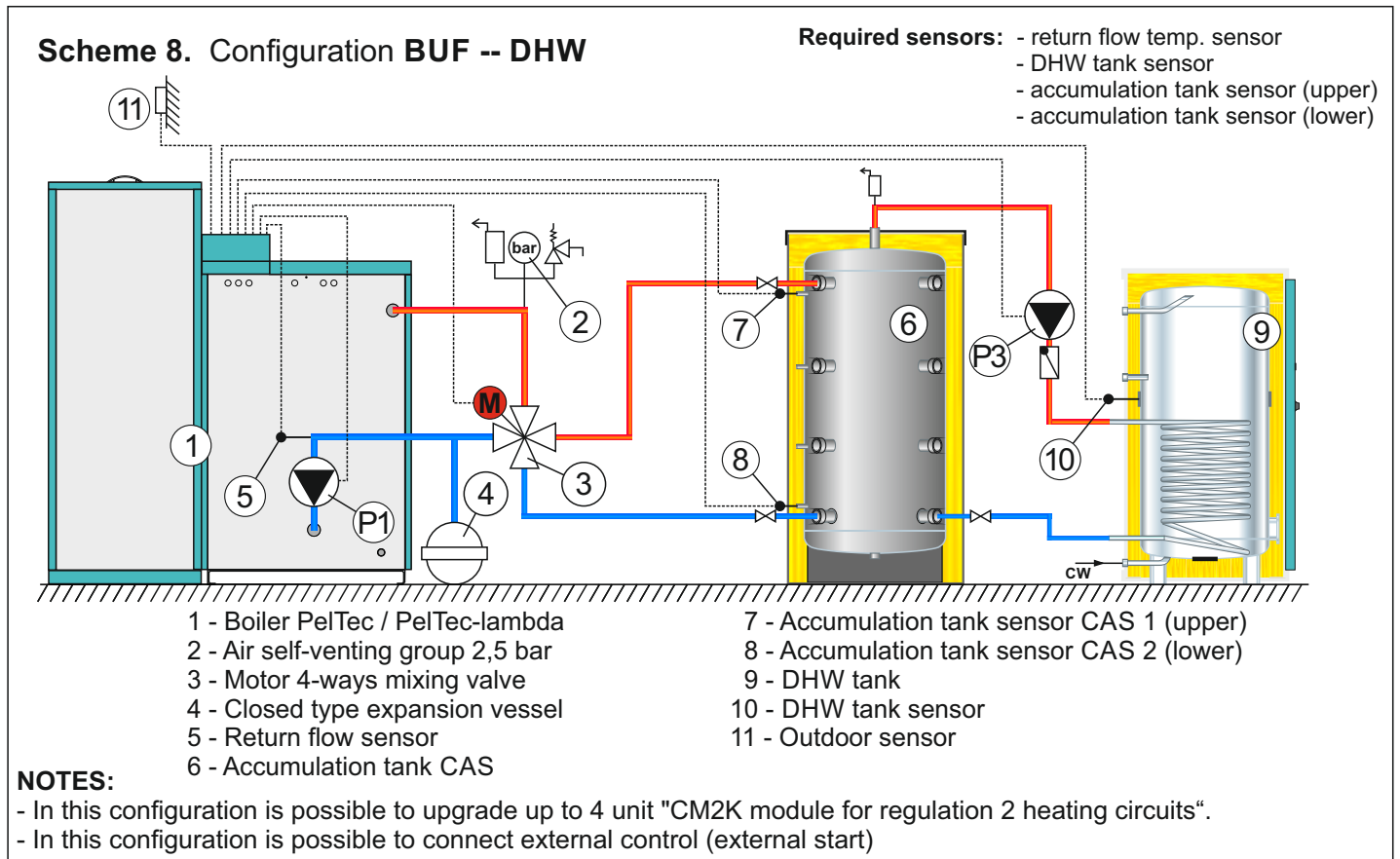

On the screen

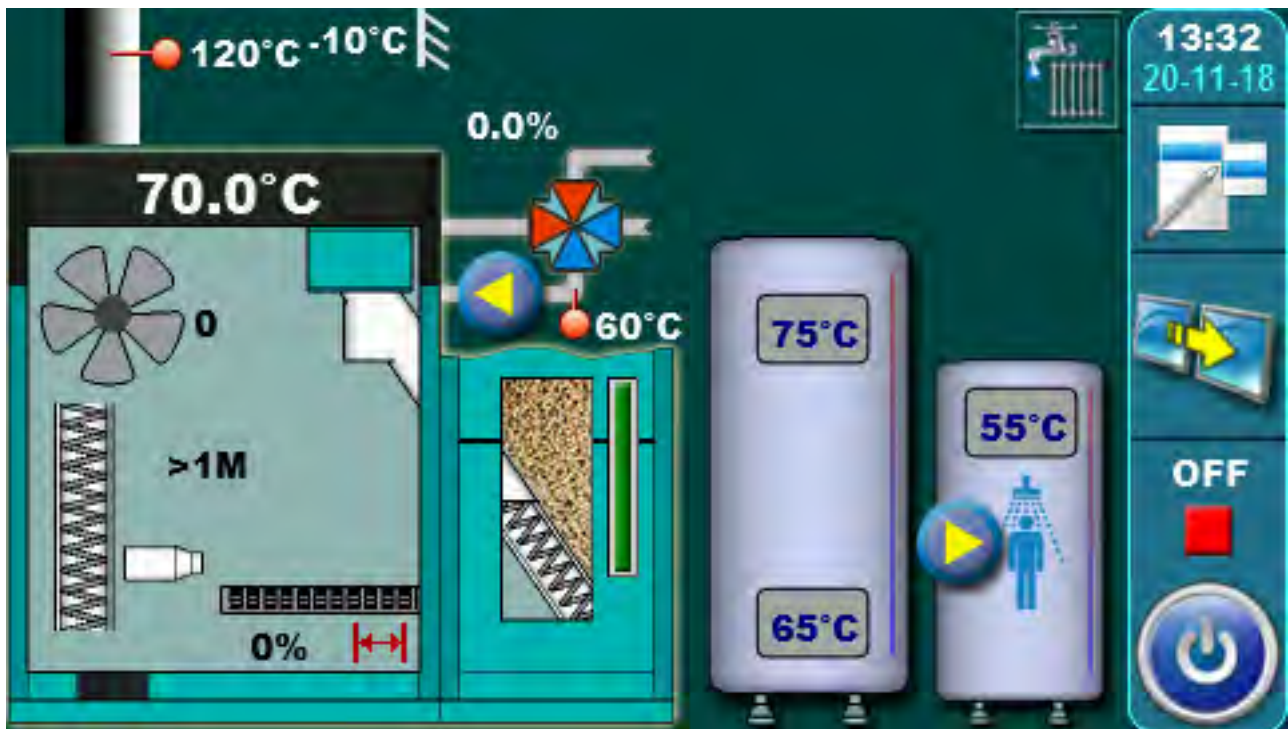

2. TEMPERATURE (CONFIGURATION BUF--DHW)

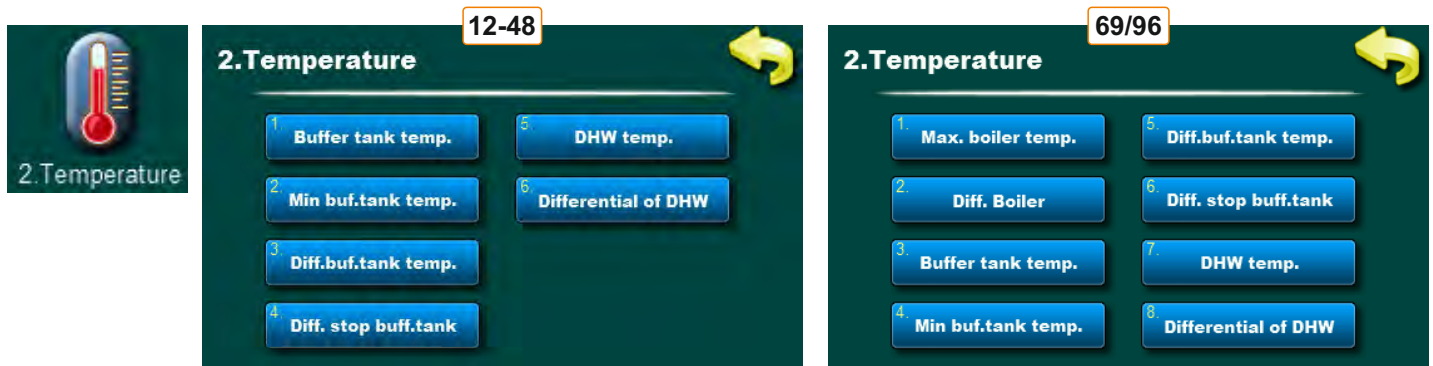

2.1 / 2.3 BUFER TANK TEMP.

Possible selection:

default: 80°C

Minimum: 40°C

Maximum: 85°C

The possibility of setting the desired temperature of the accumulation tank.

2.2 / 2.4 MIN. BUF. TANK TEMP.

Possible selection:

default: 20°C

Minimum: 5°C

Maximum: 64°C

The possibility of setting the minimum temperature of the accumulation tank.

2.3 / 2.5 DIFF. BUF. TANK TEMP.

Possible selection:

default: 10°C

Minimum: 5°C

Maximum: 30°C

The possibility of setting the accumulation tank start difference.

2.4 / 2.6 DIFF. STOP BUF. TANK

Possible selection:

default: 5°C

Minimum: 3°C

Maximum: 30°C

The possibility of setting the accumulation tank stop difference.

2.5 / 2.7 DHW TEMP.

Possible selection:

default: 50°C

Minimum: 40°C

Maximum: 80°C

Temperature setting options of DHW (domestic hot water).

2.6 / 2.8 DIFFERENTIAL OF DHW

Possible selection:

default: 5°C

Minimum: 4°C

Maximum: 40°C

The possibility of setting domestic hot water difference.

2.1 MAX. BOILER TEMP. (ONLY 69/96)

Possible selection:

default: 85°C

Minimum: 80°C

Maximum: 90°C

The possibility of setting maximum boiler temperature.

2.2 DIFF. BOILER (ONLY 69/96)

Possible selection:

default: 8°C

The view of boiler difference setting (**not possible to change**).

CONFIGURATION 9 - BUF -- IHC || DHW

Scheme of configuration

Scheme 9. Configuration BUF -- IHC || DHW

Required sensors: - return flow temp. sensor
 - DHW tank sensor
 - accumulation tank sensor (upper)
 - accumulation tank sensor (lower)

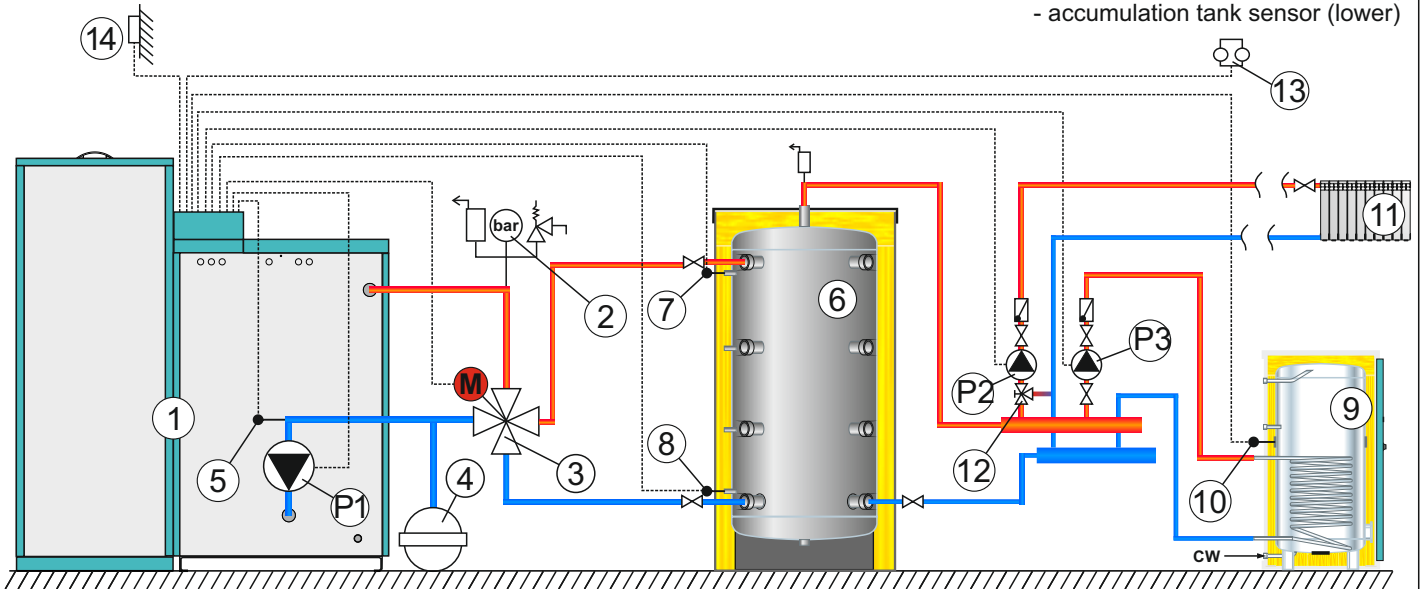

- | | |
|--|--|
| 1 - Boiler PelTec / PelTec-lambda | 8 - Accumulation tank sensor CAS 2 (lower) |
| 2 - Air self-venting group 2,5 bar | 9 - DHV tank |
| 3 - Motor 4-ways mixing valve | 10 - DHV tank sensor |
| 4 - Closed type expansion vessel | 11 - Heating circuit |
| 5 - Return flow sensor | 12 - 3-way manual mixing valve |
| 6 - Accumulation tank CAS | 13 - Room thermostat |
| 7 - Accumulation tank sensor CAS 1 (upper) | 14 - Outdoor sensor |

NOTES:

- In this configuration is possible to upgrade up to 4 unit "CM2K module for regulation 2 heating circuits".
- In this configuration is possible to connect external control (external start)

On the screen

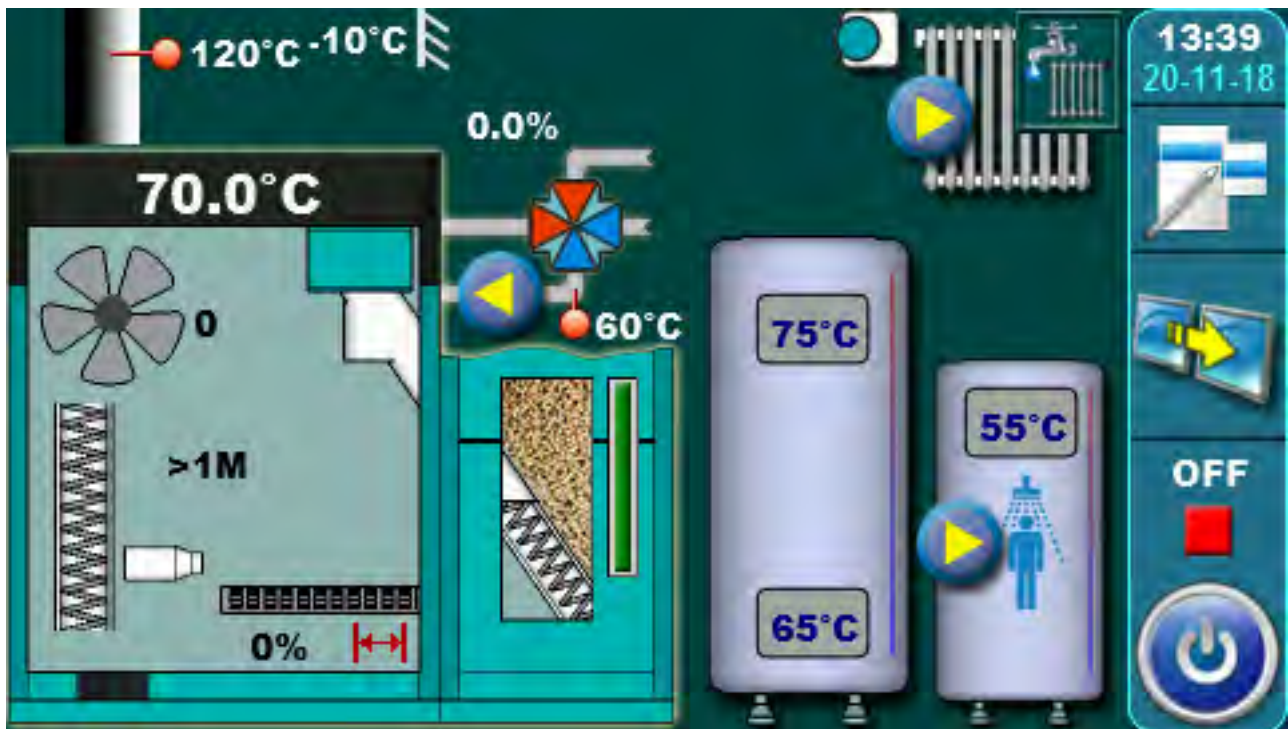

2. TEMPERATURE (CONFIGURATION BUF--IHC || DHW)

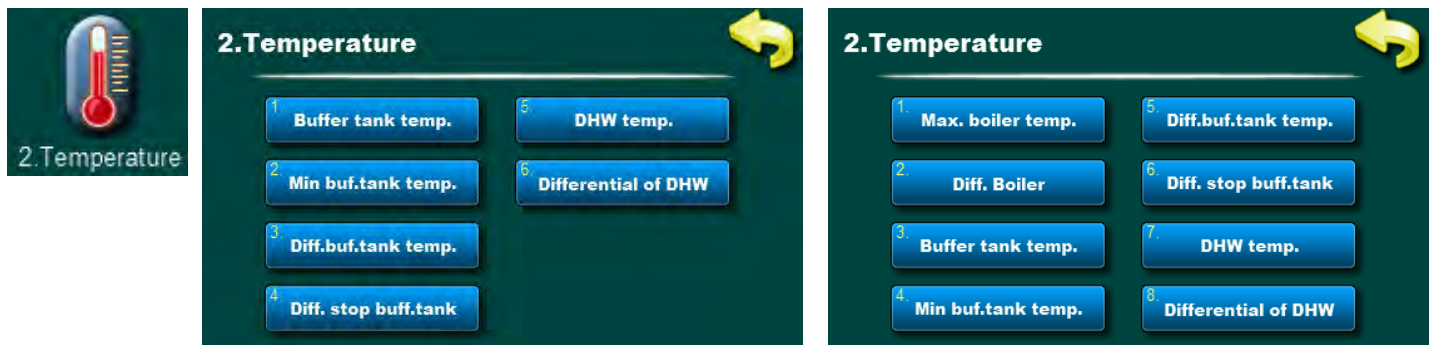

2.1 / 2.3 BUFFER TANK TEMP.

Possible selection:

default: 80°C

Minimum: 40°C

Maximum: 85°C

The possibility of setting the desired temperature of the accumulation tank.

2.2 / 2.4 MIN. BUF. TANK TEMP.

Possible selection:

default: 20°C

Minimum: 5°C

Maximum: 64°C

The possibility of setting the minimum temperature of the accumulation tank.

2.3 / 2.5 DIFF. BUF. TANK TEMP.

Possible selection:

default: 10°C

Minimum: 5°C

Maximum: 30°C

The possibility of setting the accumulation tank start difference.

2.4 / 2.6 DIFF. STOP BUFF. TANK

Possible selection:

default: 5°C

Minimum: 3°C

Maximum: 30°C

The possibility of setting the accumulation tank stop difference.

2.4 / 2.8 DHW TEMP.

Possible selection:

default: 50°C

Minimum: 40°C

Maximum: 80°C

Temperature setting options of DHW (domestic hot water).

2.5 / 2.9 DIFFERENTIAL OF DHW

Possible selection:

default: 5°C

Minimum: 4°C

Maximum: 40°C

The possibility of setting domestic hot water difference.

2.1 MAX. BOILER TEMP. (ONLY 69/96)

Possible selection:

default: 85°C

Minimum: 80°C

Maximum: 90°C

The possibility of setting maximum boiler temperature.

2.2 DIFF. BOILER (ONLY 69/96)

Possible selection:

default: 8°C

The view of boiler difference setting (**not possible to change**).

CONFIGURATION 10 - HIDRAULIC CROSSOVER (CRO)

Scheme of configuration

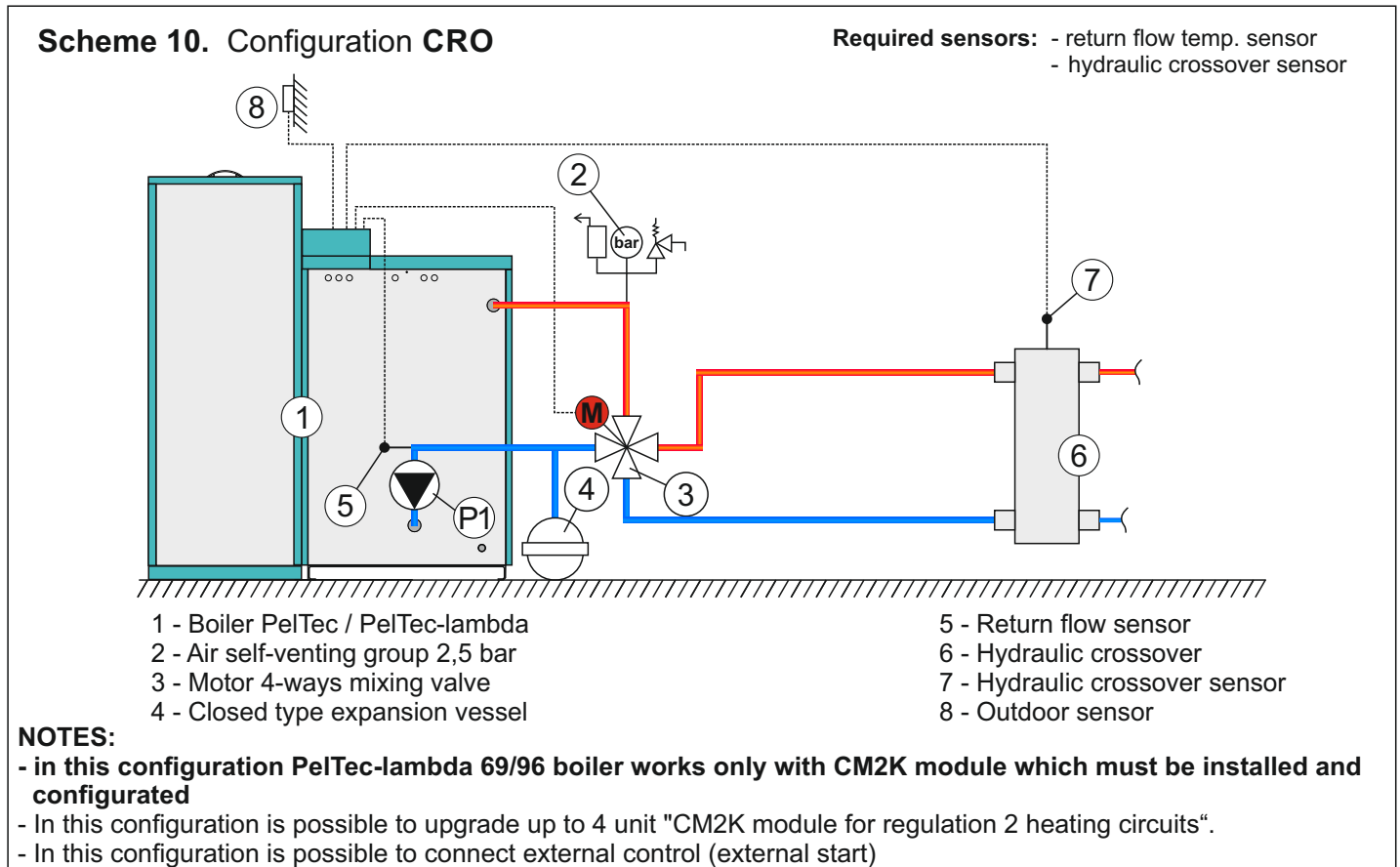

On the screen

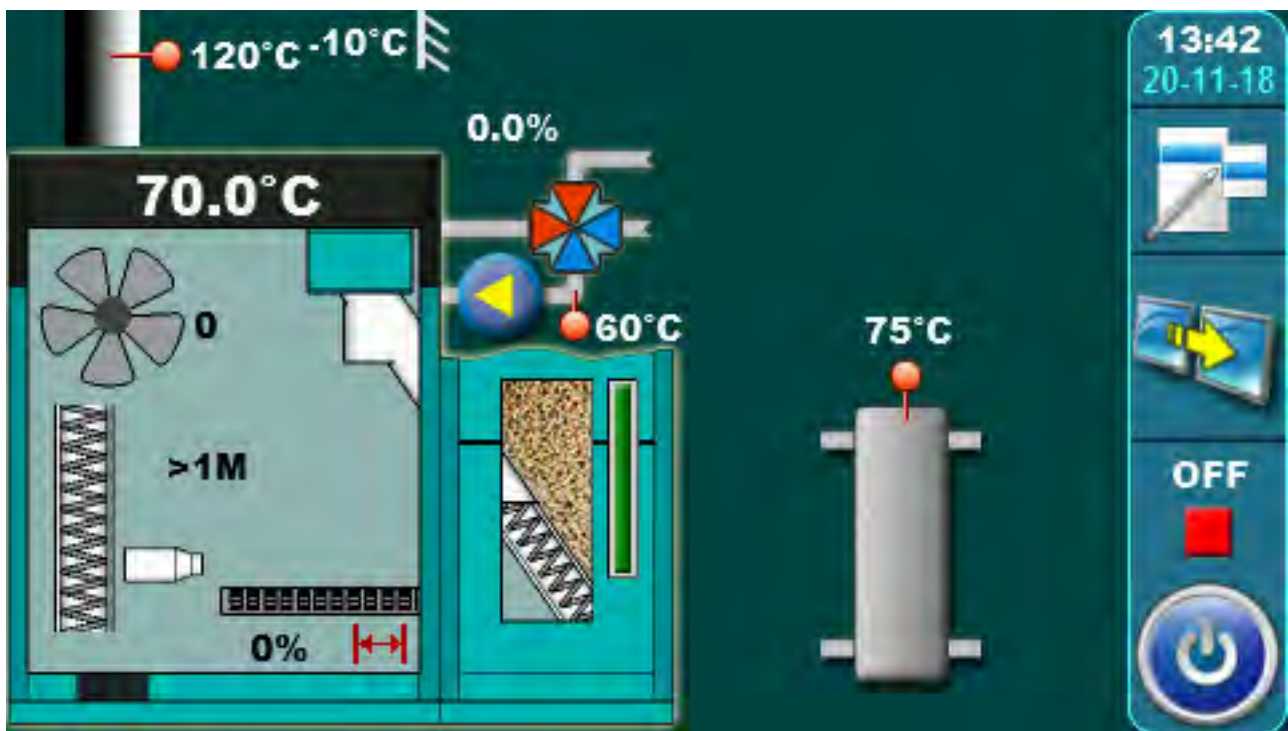

2. TEMPERATURE (CONFIGURATION HYDRAULIC CROSSOVER)

NOTE:

in this configuration PelTec-lambda 69/96 boiler works only with CM2K module which must be installed and configured

12-48

2.Temperature

1 Crossover temp.

69/96

2.Temperature

1 Max. boiler temp.

2 Diff. Boiler

3 Min. Tcro

69/96

2.Temperature

1 Max. boiler temp.

2 Diff. Boiler

3 Min. Tcro

4 Min. Tcro(dhw)

IMPORTANT:
default view of the menu when CM2K is not installed and configured
BOILER CAN'T WORK!

2.1 CROSSOVER TEMP. (ONLY 12-48)

Possible selection:

default: 80°C / Minimum: 70°C / Maximum: 85°C

The possibility of setting the hydraulic crossover temperature.

2.1 MAX. BOILER TEMP. (ONLY 69/96)

Possible selection:

default: 75°C / Minimum: 75°C / Maximum: 80°C

The possibility of setting maximum boiler temperature.

2.2 DIFF. BOILER (ONLY 69/96)

Possible selection:

default: 8°C

The view of boiler difference setting (not possible to change).

2.3 MIN. Tcro (ONLY 69/96)

Possible selection:

default: 70°C / Minimum: 40°C / Maximum: 70°C

The possibility of setting minimum crossover temperature.

2.3 MIN. Tcro (DHW) (ONLY 69/96)

Possible selection:

The view of set temperature of the minimum crossover temperature for DHW (always is set the same as DHW temperature).

NOTE: USED ONLY IN CASCADES AND EXTERNAL CONTROL

Scheme 11. Configuration CRO / BUF (12-48); -- / BUF (69/96)

Version 1: Display shows 1 temperature (hydraulic crossover)
NOT POSSIBLE AT 69/96 kW

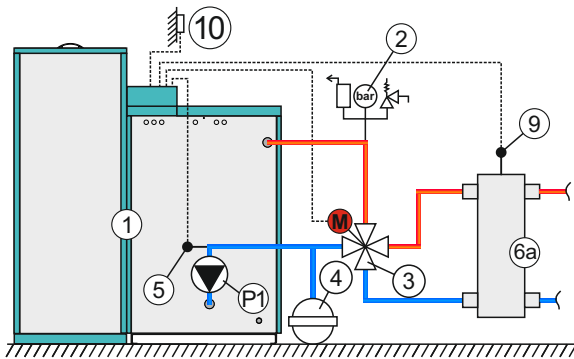

- 1 - Boiler PelTec / PelTec-lambda
- 2 - Air self-venting group 2,5 bar
- 3 - Motor 4-ways mixing valve
- 4 - Closed type expansion vessel
- 5 - Return flow sensor

Version 2: Display shows 2 temperatures (accumulation tank)

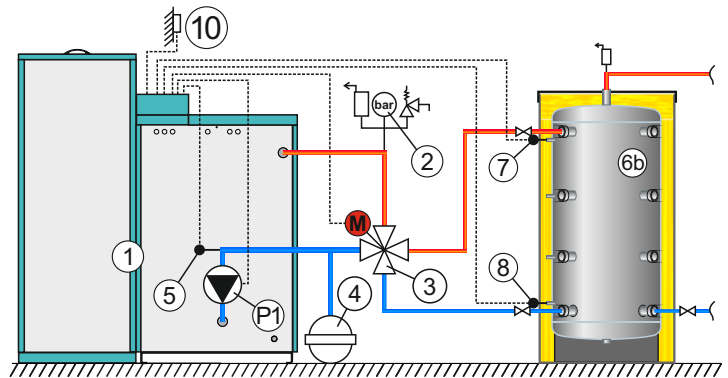

- 6a - Hydraulic crossover / 6b - Accumulation tank
- 7 - Accumulation tank sensor 1 (upper)
- 8 - Accumulation tank sensor 2 (lower)
- 9 - Hydraulic crossover sensor
- 10 - Outdoor sensor

Possible control:

- manually (ON/OFF)
- by scheduled starting times
- by external controller(START/STOP)**
- by cascade manager *
- by external controller (start/stop) + cascade manager**

Required sensors:

- return flow temp. sensor
- hydraulic crossover sensor (only in version 1)
- accumulation tank sensor (upper) (only in version 2)
- accumulation tank sensor (lower) (only in version 2)

Impossible control:

- by room thermostat

**** Additional equipment**

NOTES:

- in this configuration PelTec-lambda 69/96 boiler works only with CM2K module which must be installed and configured
- in this configuration at PelTec-lambda 69/96 boiler shown is only Accumulation tank i.e. 2 sensors (at selection -/BUF)
- In this configuration is possible to upgrade up to 4 unit "CM2K module for regulation 2 heating circuits".
- In this configuration is possible to connect external control (external start)

* Note: Connecting the sensor 9 (version 1) and 7,8 (version 2) is not required because these temperatures are only informative, if sensors are not connected, regulation will show temperature " - °C". The boiler regulation will not report any error even if the sensors are defective.

On the screen

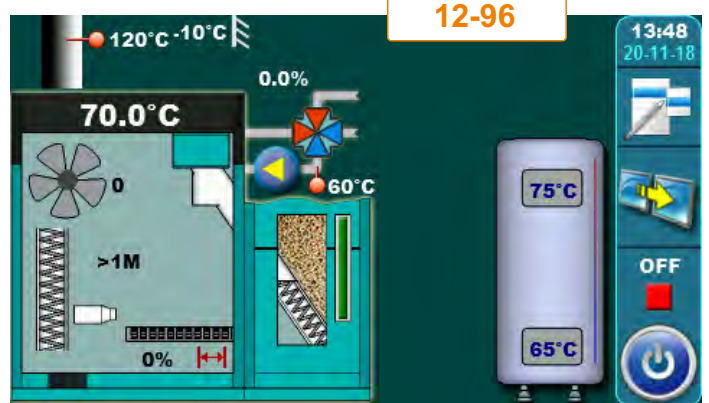
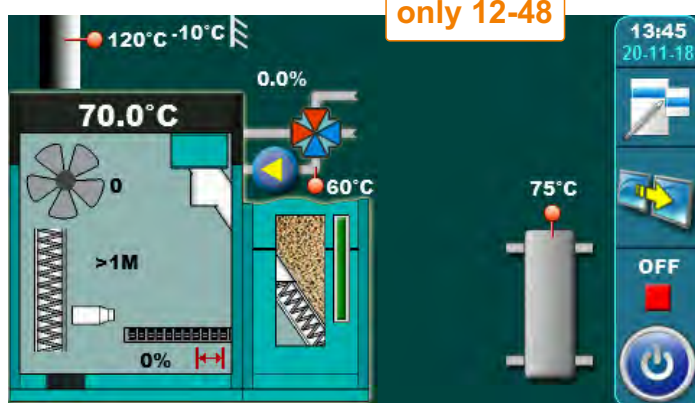

When "1 Temperature" is selected, screen shows hydraulic crossover with 1 temperature (**not possible at 69/96**).

When "2 Temperatures" is selected, screen shows accumulation tank with 2 temperatures. **This option can be changed only by authorized serviceman.**



2. TEMPERATURE (CONFIGURATION CRO/BUF (12-48); --/BUF (69/96))



2.1 MAX. BOILER TEMP.

Possible selection:

default: 80°C

Minimum: 73°C

Maximum: 90°C

The possibility of setting the maximum boiler temperature.

2.2 DIFF. BOILER

Possible selection:

default: 8°C

The view of boiler difference setting (**not possible to change**).

CONFIGURATION 12 - DHW || DHC (2)

Scheme of configuration

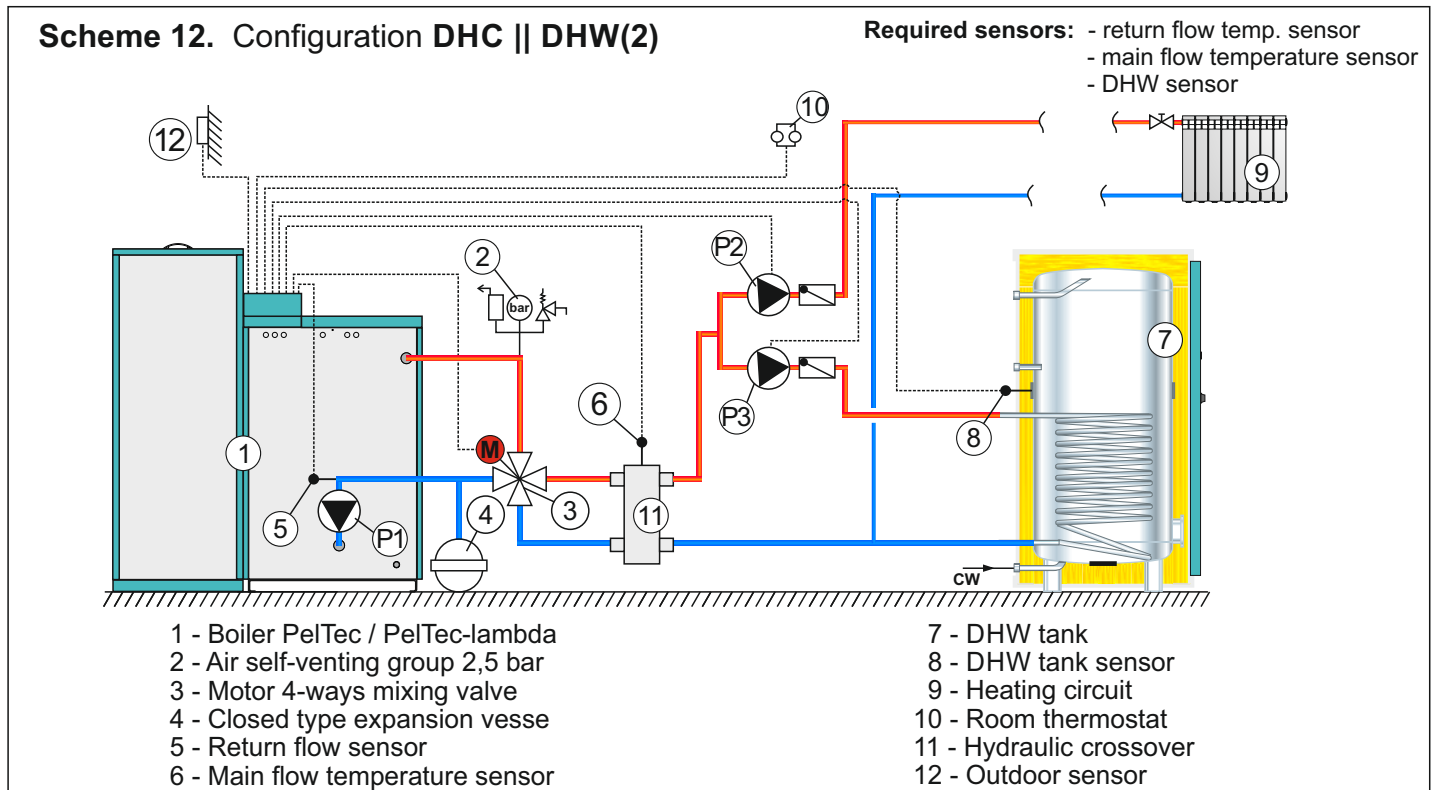

On the screen

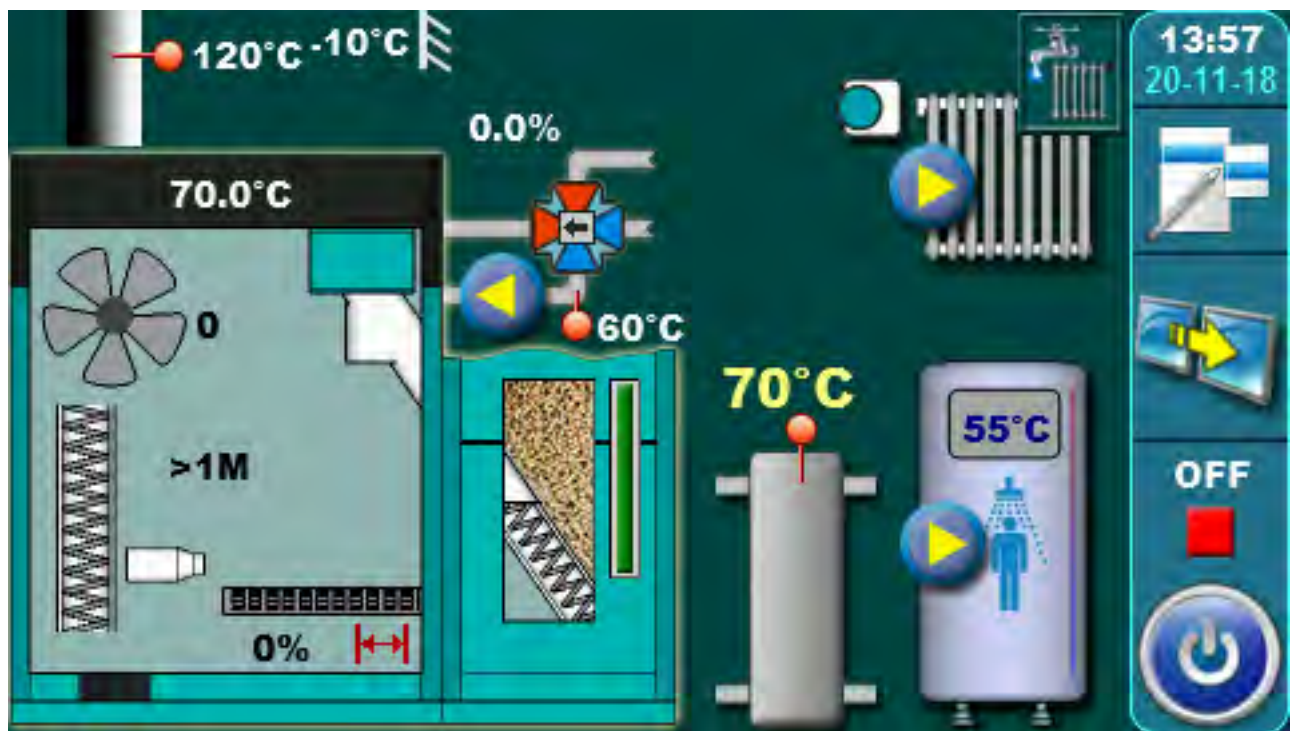

2. TEMPERATURE (CONFIGURATION DHW || DHC(2))

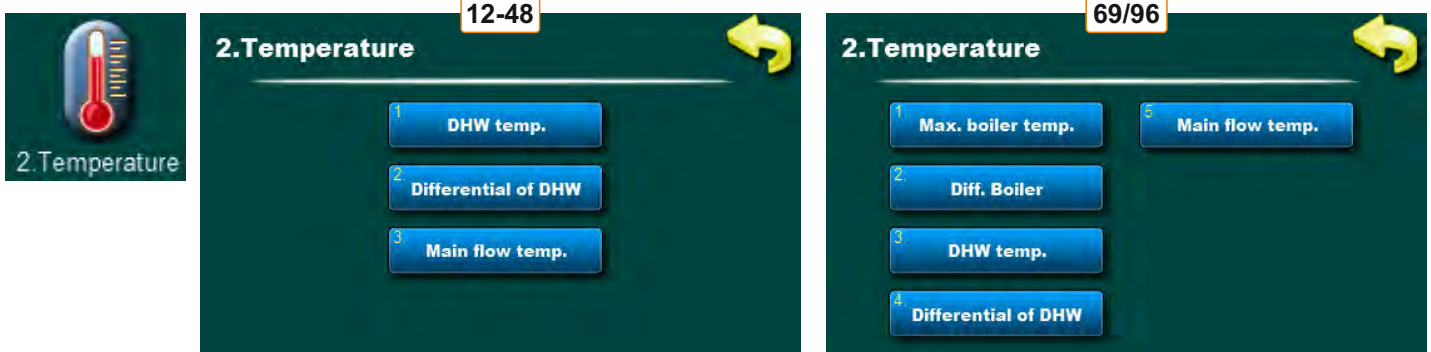

2.1 / 2.3 DHW TEMP.

Possible selection:

default: 50°C

Minimum: 40°C

Maximum: 80°C

Temperature setting options of DHW (domestic hot water).

2.2 / 2.4 DIFFERENTIAL OF DHW

Possible selection:

default: 5°C

Minimum: 4°C

Maximum: 40°C

The possibility of setting domestic hot water difference.

2.3 / 2.5 MAIN FLOW TEMP.

Possible selection:

default: 60°C

Minimum: 30°C

Maximum: 90°C

The possibility of setting main flow temperature

2.1 MAX. BOILER TEMP. (ONLY 69/96)

Possible selection:

default: 75°C

Minimum: 75°C

Maximum: 80°C

The possibility of setting maximum boiler temperature.

2.2 DIFF. BOILER (ONLY 69/96)

Possible selection:

default: 8°C

The view of boiler difference setting (**not possible to change**).

CONFIGURATION 13 - DHC 2X

Scheme of configuration

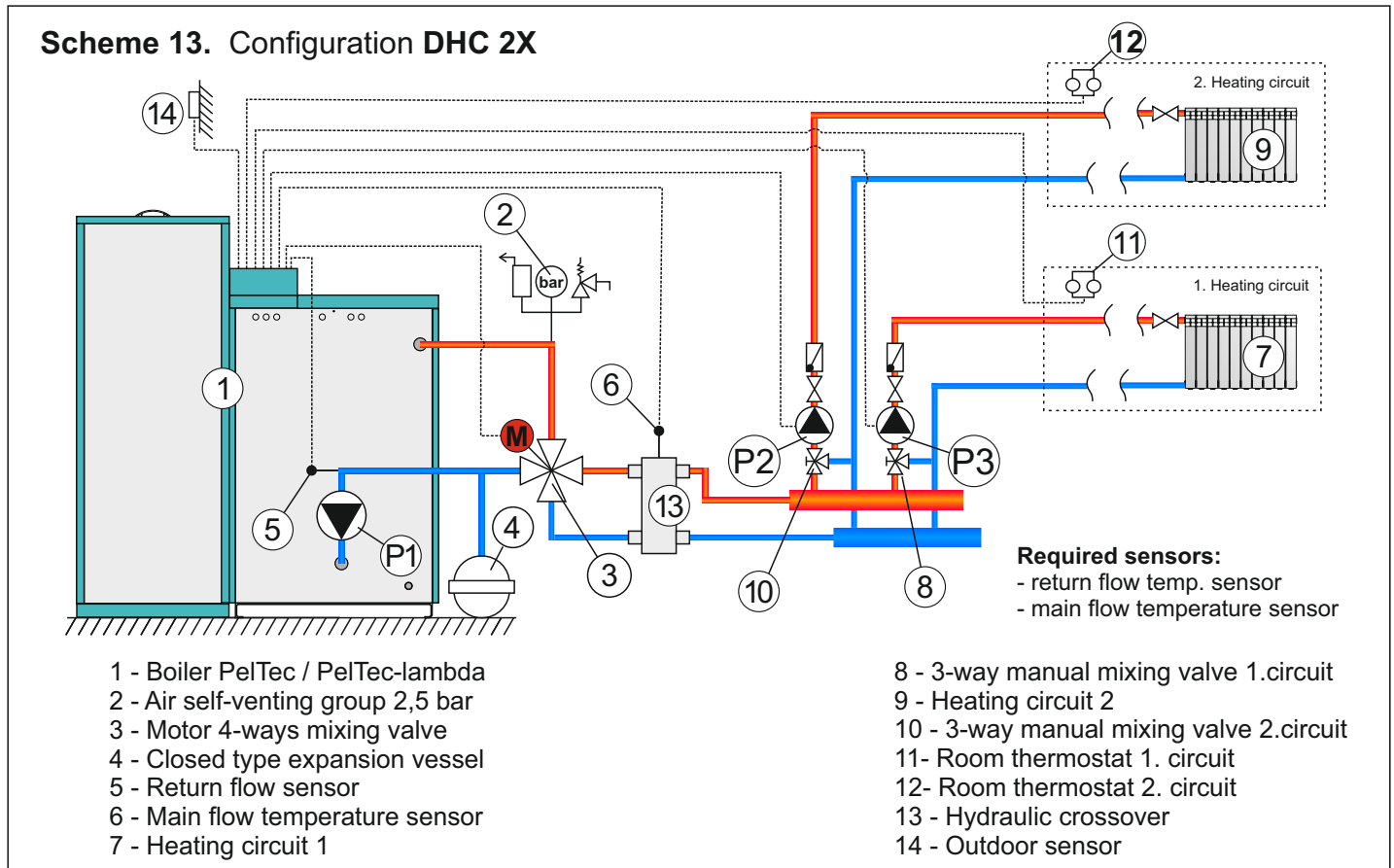

On the screen

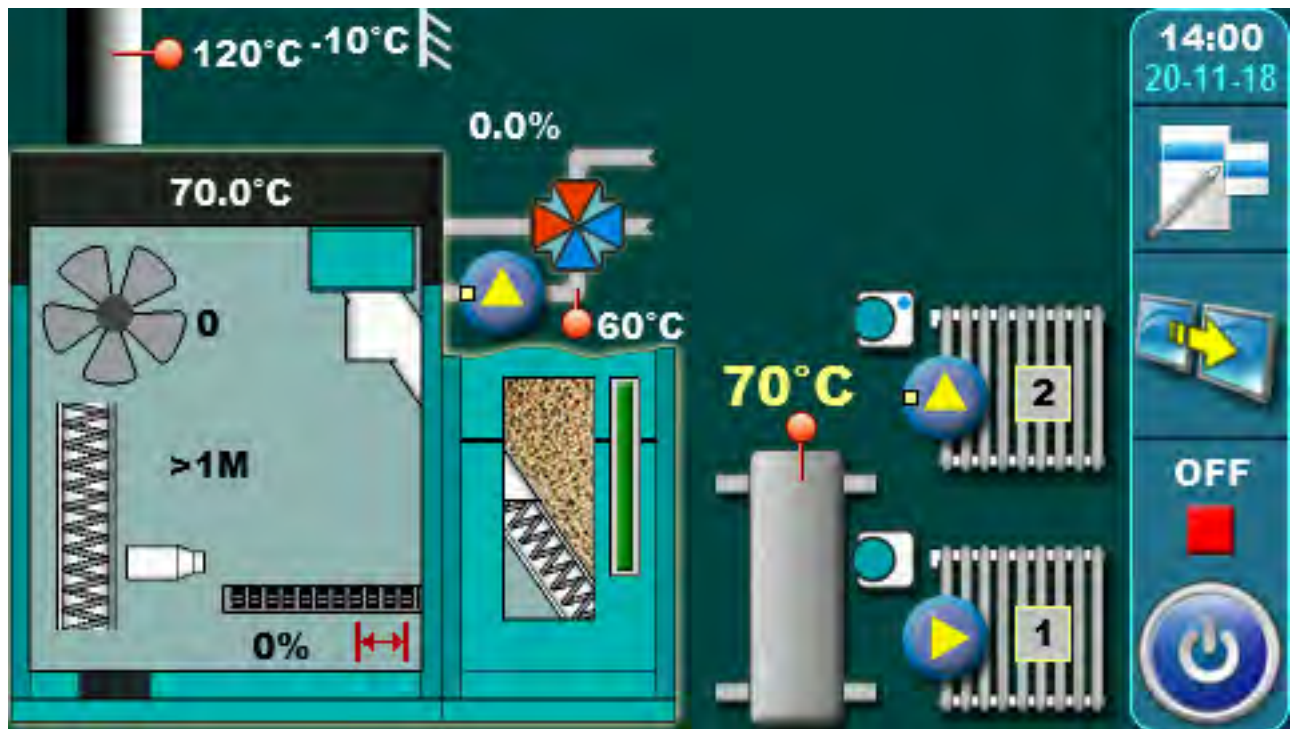

2.0 TEMPERATURES (CONFIGURATION DHC 2X)

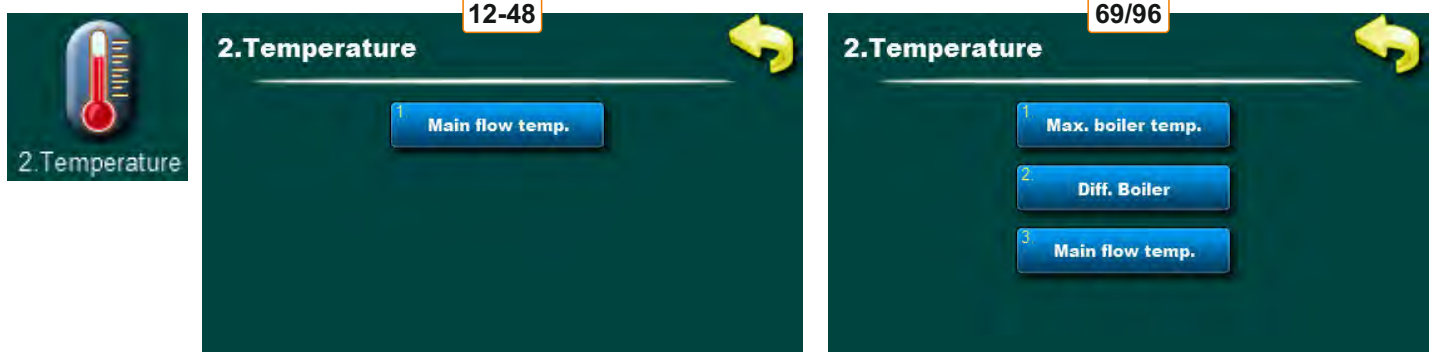

2.1 MAIN FLOW TEMP.

Possible selection:

default: 60°C

Minimum: 30°C

Maximum: 90°C

The possibility of setting main flow temperature

2.1 MAX. BOILER TEMP. (ONLY 69/96)

Possible selection:

default: 75°C

Minimum: 75°C

Maximum: 80°C

The possibility of setting maximum boiler temperature.

2.2 DIFF. BOILER (ONLY 69/96)

Possible selection:

default: 8°C

The view of boiler difference setting (**not possible to change**).

CONFIGURATION 14 - BUF--IHC 2X

Scheme of configuration

Shema 14. Configuration BUF--IHCx2

Required sensors: - return flow temp. sensor
 - accumulation tank sensor (upper)
 - accumulation tank sensor (lower)

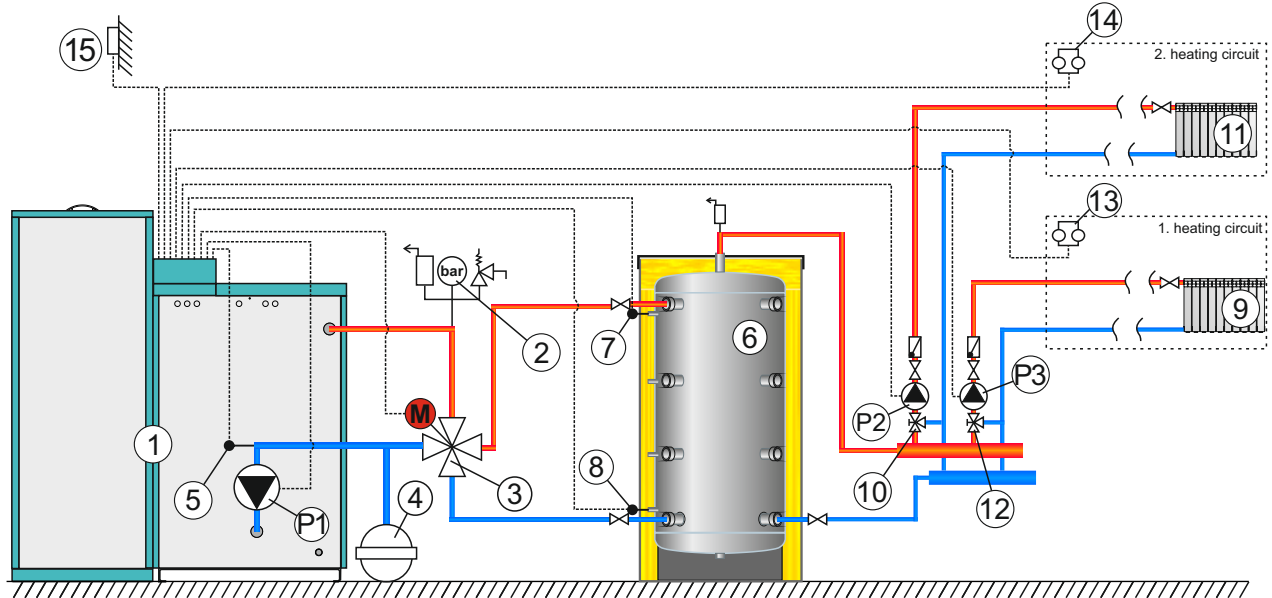

- | | |
|--|--|
| 1 - Boiler PelTec / PelTec-lambda | 9 - Heating circuit 1 |
| 2 - Air self-venting group 2,5 bar | 10 - 3-way manual mixing valve 1.circuit |
| 3 - Motor 4-ways mixing valve | 11 - Heating circuit 2 |
| 4 - Closed type expansion vessel | 12 - 3-way manual mixing valve 2.circuit |
| 5 - Return flow sensor | 13 - Room thermostat 1. circuit |
| 6 - Accumulation tank CAS | 14 - Room thermostat 2. circuit |
| 7 - Accumulation tank sensor CAS 1 (upper) | 15 - Outdoor sensor |
| 8 - Accumulation tank sensor CAS 1 (lower) | |

NOTES:

- In this configuration is possible to upgrade up to 4 unit "CM2K module for regulation 2 heating circuits".
- In this configuration is possible to connect external control (external start)

On the screen

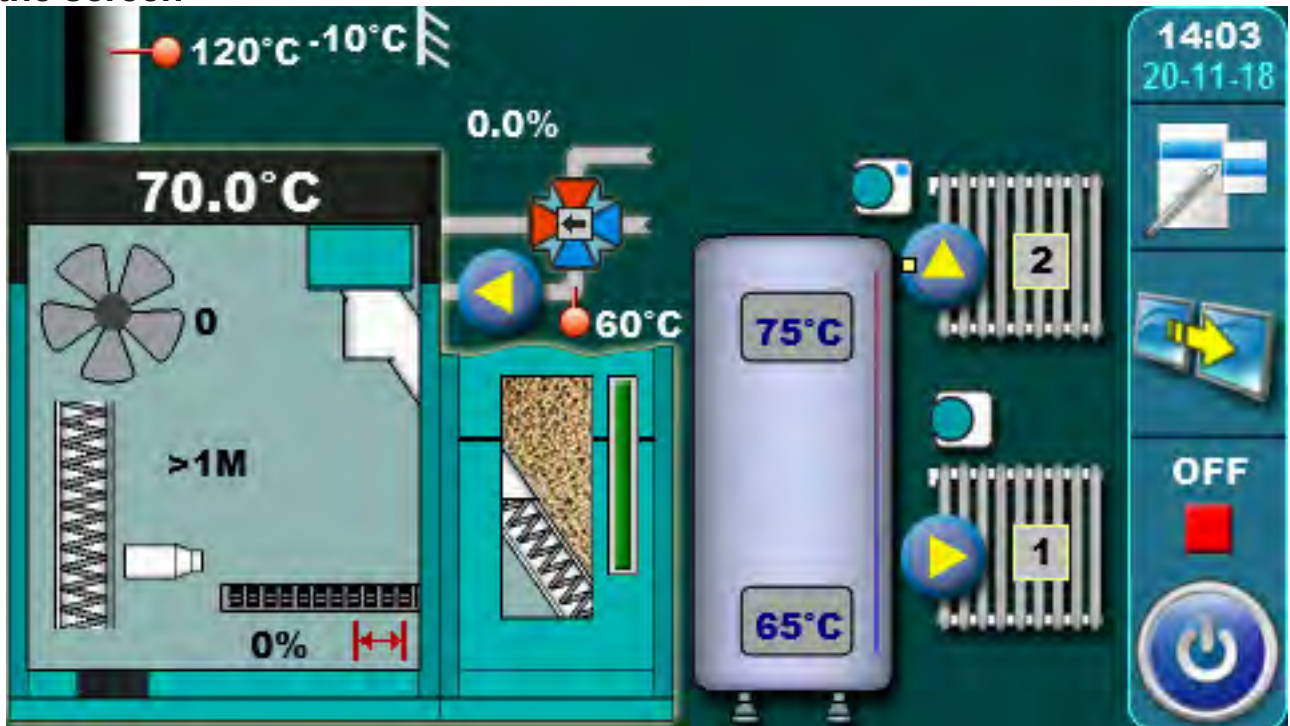

2. TEMPERATURES (CONFIGURATION BUF--IHC 2x)

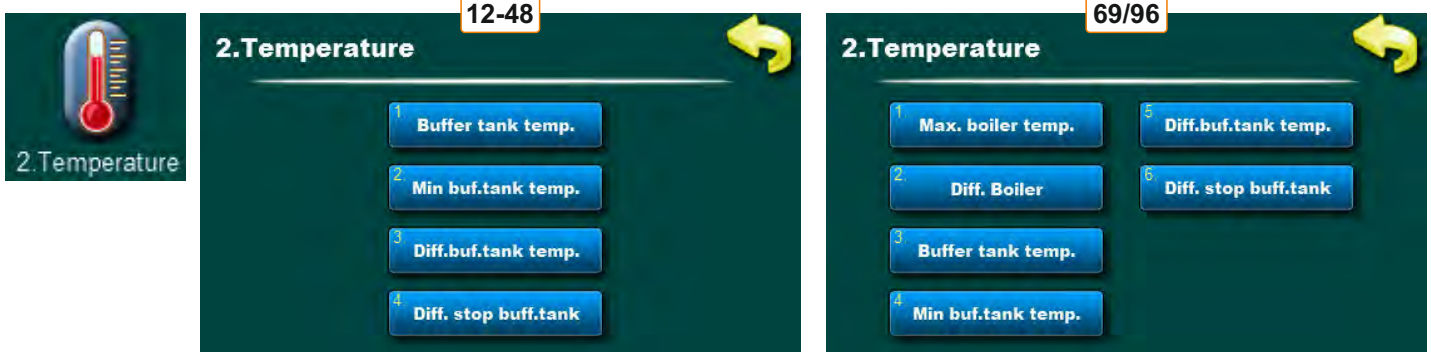

2.1 / 2.3 BUFFER TANK TEMP.

Possible selection:

default: 80°C

Minimum: 40°C

Maximum: 85°C

The possibility of setting the desired temperature of the accumulation tank.

2.2 / 2.4 MIN. BUF. TANK TEMP.

Possible selection:

default: 20°C

Minimum: 5°C

Maximum: 64°C

The possibility of setting the minimum temperature of the accumulation tank.

2.3 / 2.5 DIFF. BUF. TANK TEMP.

Possible selection:

default: 10°C

Minimum: 5°C

Maximum: 30°C

The possibility of setting the accumulation tank start difference.

2.4 / 2.6 DIFF. STOP BUF. TANK

Possible selection:

default: 5°C

Minimum: 3°C

Maximum: 30°C

The possibility of setting the accumulation tank stop difference.

2.1 MAX. BOILER TEMP. (ONLY 69/96)

Possible selection:

default: 85°C

Minimum: 80°C

Maximum: 90°C

The possibility of setting maximum boiler temperature.

2.2 DIFF. BOILER (ONLY 69/96)

Possible selection:

default: 8°C

The view of boiler difference setting (**not possible to change**).

CONFIGURATION 15 - CRO--DHW

Scheme of configuration

Scheme 15. Configuration CRO -- DHW

Required sensors: - return flow temp. sensor
- DHW tank sensor
- hydraulic crossover sensor

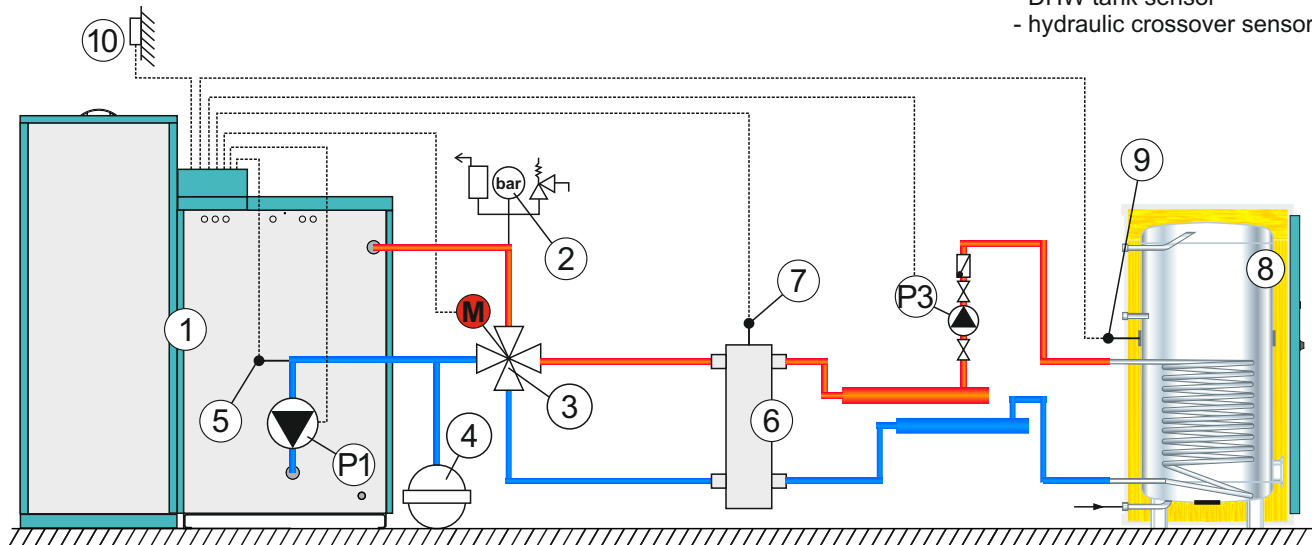

- 1 - Boiler PelTec / PelTec-lambda
- 2 - Air self-venting group 2,5 bar
- 3 - Motor 4-ways mixing valve
- 4 - Closed type expansion vessel
- 5 - Return flow sensor

- 6 - Hydraulic crossover
- 7 - Hydraulic crossover sensor
- 8 - DHW tank
- 9 - DHW tank sensor
- 10 - Outdoor sensor

NOTE:

- in this configuration boiler PelTec-lambda 69/96 can work only by DHW demand (except if CM2K is installed)
- in this configuration to be able to heat heating system, module CM2K must be installed and configured
- in this configuration is possible to upgrade up to 4 unit "CM2K module for regulation 2 heating circuits

On the screen

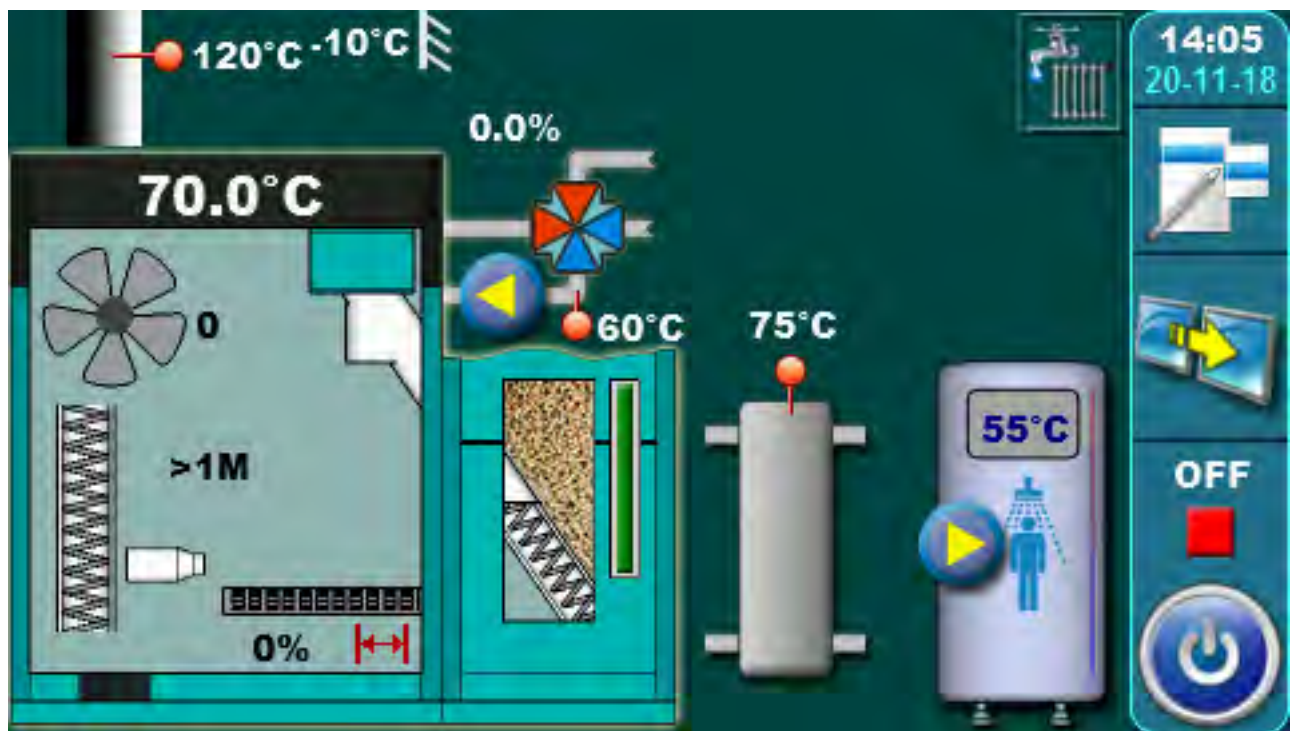

2. TEMPERATURE (CONFIGURATION CRO -- DHW)

NOTE:

In this configuration boiler PelTec-lambda 69/96 can work only by DHW demand. In this configuration module CM2K must be installed and configured to be able to heat heating system.

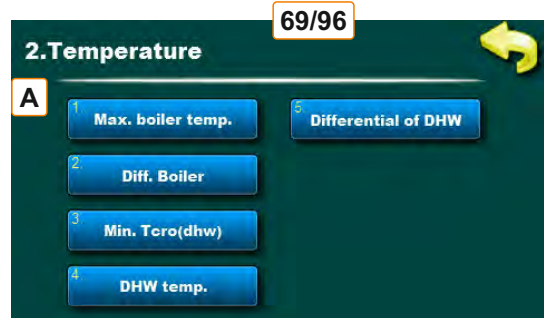
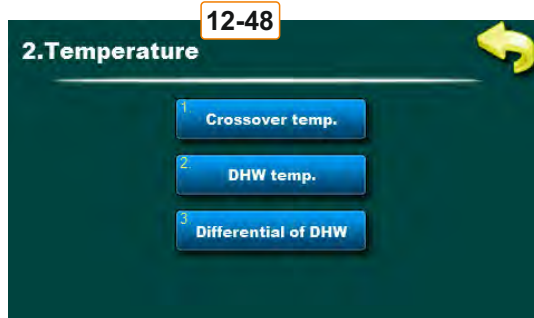
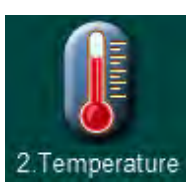

A - view when CM2K is configured only for heating circuits

B - view when CM2K is configured for heating circuit and DHW circuit

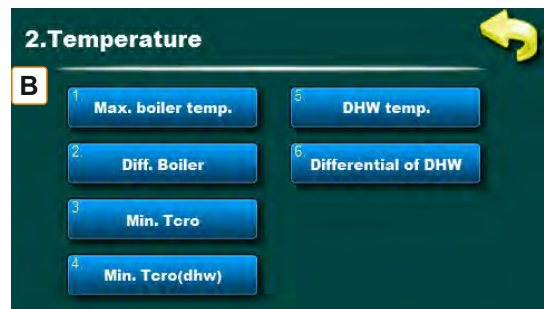

2.1 CROSSOVER TEMP. (ONLY 12-48)

Possible selection:

default: 80°C
Minimum: 70°C
Maximum: 85°C

The possibility of setting the hydraulic crossover temperature.

2.2 / 2.4 DHW TEMP.

Possible selection:

default: 50°C
Minimum: 40°C
Maximum: 80°C

Temperature setting options of DHW (domestic hot water).

2.3 / 2.5 DIFFERENTIAL OF DHW

Possible selection:

default: 5°C
Minimum: 4°C
Maximum: 40°C

The possibility of setting domestic hot water difference.

2.1 MAX. BOILER TEMP. (ONLY 69/96)

Possible selection:

default: 75°C

Minimum: 75°C

Maximum: 80°C

The possibility of setting maximum boiler temperature.

2.2 DIFF. BOILER (ONLY 69/96)

Possible selection:

default: 8°C

The view of boiler difference setting (**not possible to change**).

2.3 / 2.4 MIN. Tcro DHW (ONLY 69/96)

Possible selection:

default: -°C

Minimum: -°C

Maximum: -°C

The view of set temperature of the minimum crossover temperature for DHW (always is set the same as DHW temperature).

2.3 MIN. Tcro (ONLY 69/96)

Possible selection:

default: 70°C

Minimum: 45°C

Maximum: 70°C

The possibility to set hydraulic crossover minimum temperature.

3.0. SCHEDULE

Possible selection:

Boiler - schedule for boiler working

DHW - schedule for DHW pump working

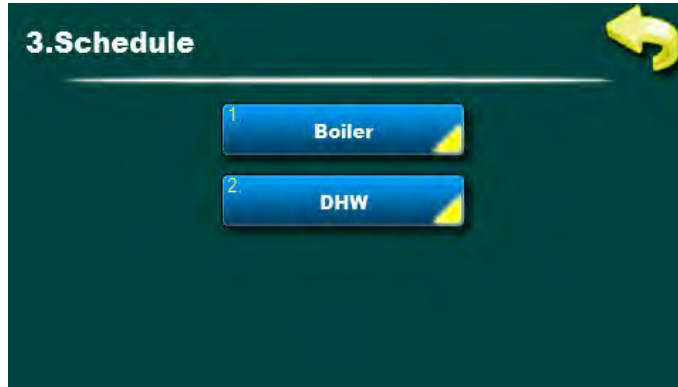

3.1. SCHEDULE BOILER

Possible selection:

Disable - Schedule is turned off (**default**)

Table 1 - Table 1 is enabled and boiler is working according to the settings in Table 1

Table 2 - Table 2 is enabled and boiler is working according to the settings in Table 2

Table 3 - Table 3 is enabled and boiler is working according to the settings in Table 3



3.2 SCHEDULE DHW

Possible selection:

OFF - schedule is disabled (**factory setting**)

Table 1 - Table 1 is enabled and DHW pump works according Table 1 setting

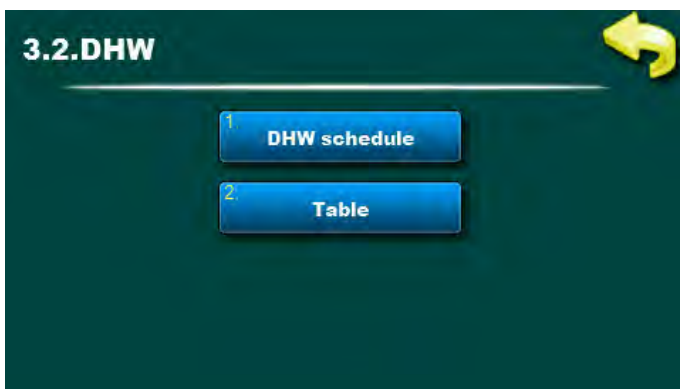



**ALWAYS WHEN SCHEDULE IS ENABLED (TABLE 1, 2 OR 3)
SYMBOL WILL APPEAR ON THE MAIN SCREEN**

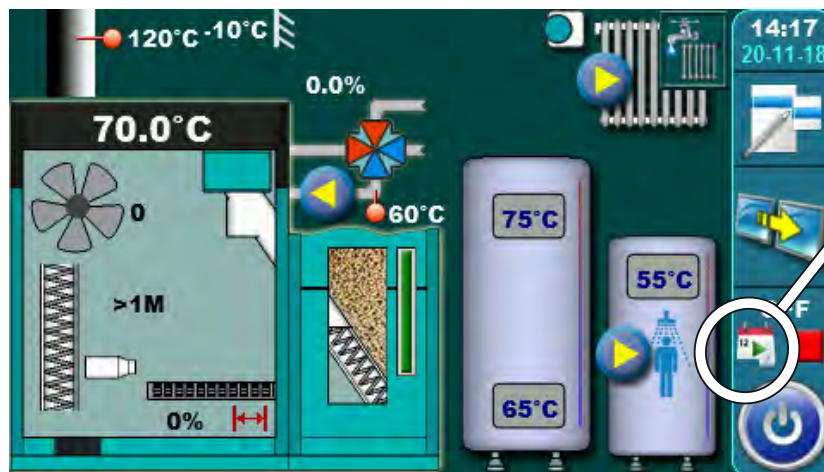
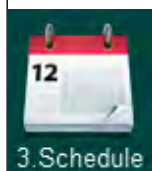

3.2. - 3.4. TABLE 1, 2, 3

Possibility of schedule is done using tables. They can be pre-set 3 tables of schedule of which only one table can be active. It is possible for every day of the week set 3 turning-on and 3 turning-off the boiler. Turn-on is marked by a green field and turn-off is marked with red field. You can adjust the starting times for one day and copied the same starting times to all other days. After setting the starting times for one day you have to click on the field that day (the whole day will be marked), on the right side will show the button "COPY". Press this key (now you have copied the setting of that day and now will show button "PASTE"). It is necessary to press the day for which you want this settings and press the button "PASTE". After that, the same starting time will be copied in the selected day. If you want the same settings for the other days, just select the desired day and press button "PASTE". After filling the table with the starting times, press button "BACK", and press button "CONFIRM" for saving this settings.

Schedule - Table 1							
	MON	TUE	WED	THU	FRI	SAT	SUN
06:00	06:00	06:00	06:00	06:00	06:00	06:00	06:00
22:00	22:00	22:00	22:00	22:00	22:00	22:00	22:00

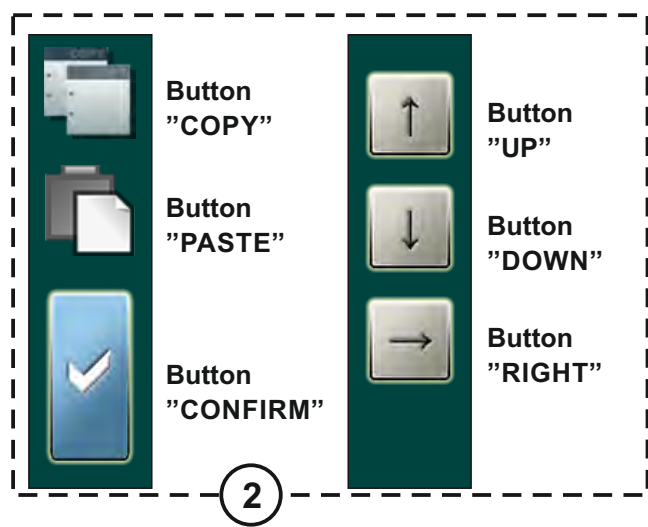
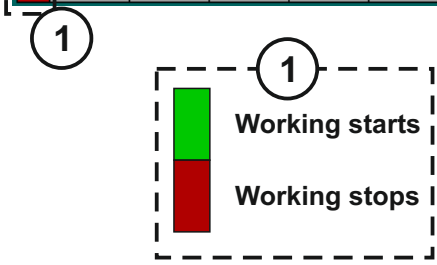

4.0. HISTORY

Error list / warnings used in order to have an insight into the errors / warnings that have occurred. Written is: time of occurrence errors / warnings, error code / warning; description of the error / warning. The first press on the field error / warning field error / warnings is indicated, in addition to see and date generated errors / warnings. The second press on the selected error / warning, prints a detailed description of the error / warnings and corrective action errors / warnings.

E - conditions that result the shutdown of the boiler. The error must be rectified before the next boiler starts.

ERROR	NAME	DESCRIPTION
E1	DHW sensor error	Boiler status: Boiler go to phases S7, C0 and OFF. Possible causes: Interruption on el. connections between sensor and boiler, connection to the boiler, cold connection or DHW sensor is invalid.
E2	Buffer tank sensor error (Up)	Boiler status: Boiler go to phases S7, C0 and OFF. Possible causes: Interruption on el. connections between sensor and boiler, cold connection or buffer tank sensor (up) is invalid.
E3	Buffer tank sensor error (Down)	Boiler status: Boiler go to phases S7, C0 and OFF. Possible causes: Interruption on el. connections between sensor and boiler, cold connection or buffer tank sensor (down) is invalid.
E4	Flue gas sensor error	Boiler status: Boiler go to phases S7, C0 and OFF. Possible causes: Interruption on el. connections between sensor and boiler, cold connection or invalid flue gas sensor.
E5	Outside temperature sensor error	Boiler status: Boiler work normally, problem appears on work of CM2K regulator if is installed. Possible causes: Interruption on el. connections between sensor and boiler, cold connection or invalid outside temperature sensor.
E6	Main flow sensor error	Possible causes: Interruption on el. connections between sensor and boiler, cold connection or invalid main flow sensor.
E7	Return flow sensor error	Boiler status: Boiler go to phases S7, C0 and OFF. Possible causes: Interruption on el. connections between sensor and boiler, connection to the boiler, cold connection or invalid return flow sensor.
E8	Pellet supply tube temperature too high	Boiler status: Staying in phase OFF (can be appear in OFF phase because of bimetal sensor information about too high temperature). Possible causes: Feeding tube temperature is higher than 80°C, interruption on el. connections between bimetal sensor and boiler, connection to boiler, cold connection or invalid bimetal sensor.

E8-1	Pellet supply tube temperature too high	Boiler status: Boiler go to phases S7, C0 and OFF (it's appear after 18 notice and completion of adjusted retry ignition number). Possible causes: Feeding tube temperature is higher than 80°C, interruption on el. connections between bimetal sensor and boiler, connection to boiler, cold connection or invalid bimetal sensor.
E8-2	Pellet supply tube temperature too high	Boiler status: Boiler go from phase S0 to OFF (it's appear after 18 notice and completion of adjusted retry ignition number because of bimetal sensor information about too high temperature in phase S0). Possible causes: Feeding tube temperature is higher than 80°C, interruption on el. connections between bimetal sensor and boiler, connection to boiler, cold connection or invalid bimetal sensor.
E9	Boiler sensor error	Boiler status: Boiler go to phases S7, C0 and OFF. Possible causes: Interruption on el. connections between sensor and boiler, connection to the boiler, cold connection or invalid sensor.
E10	Unknown boiler power	Boiler status: Boiler immediate go to phase OFF. Possible causes: Key for power loading is not installed or recognized, cold connection or invalid key.
E11	Photocell error	Boiler status: Boiler go to phase OFF after ending phase S0 (retry start is allowed). Possible cause: Invalid photocell (sending information that flame exist in phase S0).
E12	Safety pressure switch	Boiler status: Boiler immediate go to phase OFF. Possible causes: Firebox resistance is too low in phases S2, S3, S4, (S5). If any door or any opening for cleaning on boiler is not properly closed, turbulators area is not closed or PVC tube for pellet supply has holes. Interruption in el. connection between safety pressure switch and boiler, connection to the boiler, cold connection or invalid safety pressure switch. Interruption or bad sealing of safety pressure switch pipe.
E13	Fan error	Boiler status: Boiler immediate go to phase OFF.
E14	Memory error	Boiler status: Boiler immediate go to phase OFF.
E15	Communication error with motherboard	Boiler status: Boiler immediate go to phase OFF.
E16	Communication error with sensor board	Boiler status: Boiler go to phases S7, C0 and OFF.
E17* Only on PelTec-lambda	Lambda probe error	a) Error occurs in the phase of "OFF" - The problem is with the communication system within the lambda (Cables, connectors, el. boards, software) b) Error occurs in all phases except "OFF" - The problem is with el. heater which is integrated into the lambda probe or with the communication system within the lambda (Cables, connectors, el. boards, software)
E18	No flame in ignition phase	Boiler status: Boiler immediate go to phase OFF.
E19	Flame disapeared working phase	Boiler status: Boiler immediate go to phase OFF.

History

E20	Flame disappeared 220V	Boiler status: Boiler immediate go to phase OFF.
E21	Error grate cleaner	Boiler status: Boiler immediate go to phase OFF.
E22	Fuel level	Boiler status: Boiler go to phases S7, C0 and OFF.
E23	Flame disappeared in ignition phase	Boiler status: Boiler immediate go to phase OFF.
E24	Flame disappeared stabilization phase	Boiler status: Boiler immediate go to phase OFF..
E25	Hydra. switch sensor error	Boiler status: Boiler immediate go to phase OFF.
E26	Fuel sensor	Boiler status: Boiler immediate go to phase OFF.
E28	Communication error with CM2K (1+&2+)	Boiler status: Boiler work normally.
E37	Motherboard needs update	ONLY 69/96 - Boiler status: Boiler can't work. Call authorized serviceman to replace the mainboard.
E38	This configuration needs functional CM2K	ONLY 69/96 - Boiler status: Boiler can't work. In this configuration CM2K must be installed and configured for boiler to be able to work.
E39	Screw refill	

Errors of additional equipment: CMNET (modul for boiler cascade)

E27	Communication error with CMNET	Boiler status: Boiler immediate go to phase OFF.
------------	--------------------------------	---

Errors of additional equipment: CM2K

E29-1	Sensor reg. 1. circuit	<p>Boiler status: Boiler work normally. The problem occurs in the work of additional equipment CM2K if embedded.</p>
E29-2	Sensor reg. 2. circuit	
E29-3	Sensor reg. 3. circuit	
E29-4	Sensor reg. 4. circuit	
E29-5	Sensor reg. 5. circuit	
E29-6	Sensor reg. 6. circuit	
E29-7	Sensor reg. 7. circuit	
E29-8	Sensor reg. 8. circuit	
E30-1	Corrector reg. 1. circuit	
E30-2	Corrector reg. 2. circuit	
E30-3	Corrector reg. 3. circuit	
E30-4	Corrector reg. 4. circuit	
E30-5	Corrector reg. 5. circuit	
E30-6	Corrector reg. 6. circuit	
E30-7	Corrector reg. 7. circuit	
E30-8	Corrector reg. 8. circuit	

Errors of additional equipment: Pelet suction system

E31	The flap is not closed	<p>Boiler status: Boiler work normally. The problem occurs in the work of additional equipment - "pellet suction system" if installed.</p> <p>Possible causes: Check if the flap is blocked with pellets , if the sensor is soiled with dust, if the sensor is about 1 mm distant from the flap, if the sensor reacts on the flap (the LED lamp is switching on the sensor).</p>
E32	There are no pellets in the big tank/room	<p>Boiler status: Boiler work normally. The problem occurs in the work of additional equipment - "pellet suction system" if installed.</p> <p>Possible causes: Check the pellet level in the big tank/room , check if the flexible tubes are blocked, check if the turbine net is full with dust.</p>
E33	The Mole or Feeder screw does not work	<p>Boiler status: Boiler work normally. The problem occurs in the work of additional equipment - "pellet suction system" if installed.</p> <p>Possible causes: Check the electric connections on the mole/feeder screw, check the filthiness of the mole/feeder screw</p>
E34	Communication error with the CMVAC	<p>Boiler status: Boiler work normally. The problem occurs in the work of additional equipment - "pellet suction system" if installed.</p> <p>Possible causes:Check the UTP cable and its connections with the electric boards.</p>

History

Errors of additional equipment: CM-GSM

E35	Communication error with CM-GSM	Boiler status: Boiler work normally.
------------	---------------------------------	---

Errors of additional equipment: INTERNET SUPERVISION (WiFi)

E36	Communication error with WiFi	Boiler status: The problem occurs in the work of additional equipment internet supervision (WiFi) if installed. Possible causes: Check the UTP cable and its connections with the electric boards.
------------	-------------------------------	---

INFORMATION / WARNING

W-state information boiler that does not stop the operation of the boiler

WARNINGS

W1	Fuel level	Boiler status: Boiler will be work for a while, if pellet tank don't be refilled with pellets will be shown „E22 Fuel level” what's mean that is no enough fuel for continue of boiler work. Possible causes: Low fuel level in pellet tank, enough for short time.
W2	No flame ignition stage	Boiler status: Fire didn't appear after the adjusted max. time. Boiler will repeat ignition the adjusted number of times before error E18 appear. Possible causes: Poor pellets in the burner for a proper burning, moist pellets or bad electric heater.
W2_1	Retry ignition	Boiler status: The boiler adds a certain amount of pellets and starts the ignition again adjusted number of times and then error E18 appear. Possible causes: Poor pellets in the burner for a proper burning, moist pellets or bad electric heater.
W5	Factory setting loaded	Boiler status: The boiler works normally with loaded factory default settings
W6	Low return temperature	Boiler status: Boiler will be work normally (cause is necessary eliminate because, in longer work of boiler, will be condensation appear in boiler and flue gas tubes clogging). Possible causes: Problem with 4-way mixing valve / motor device, problem with return flow temperature sensor.
W7	Low buffer temperature	Boiler status: Boiler works normal. Pumps for heating circuits stops. DHW pump is working normally according it's conditions and demand.
W8	Pressure switch	ONLY 69/96 - Boiler status: Boiler works normal. Pressure switch warning is constantly displayed on screen until next startup. Cause of the warning must be resolved (dirty boiler, cloged holes on the burner grate, connection between boiler and chimney is dirty, chimney is dirty...).

5.0. OPERATION



NOTE: some submenus in Operation menu are shown or hidden according items enabled in Installation menu.

5.1. DHW/HEATING

Possible selection:

DHW+Heating - boiler works as needed for heating and domestic hot water

DHW only - boiler works only when there is demand for domestic hot water

Heating only - boiler works only when there is demand for heating

Auto - boiler switches automatically between DHW+Heating and DHW only working modes

DHW priority - available only in configuration 12 to set priority of DHW heating

*DHW priority - boiler works as needed for heating and DHW but with DHW priority

This option is used to set the boiler workin mode as needed, for **heating and domestic hot water, only for domestic hot water, only for heating or auto mode.**

*Option DHW / HEATING is available only in configurations that contain DHW and Heating (configurations 3, 5, 7, 9, 12, 15)

*Only configurations 3, 5, 7, 9, 12, 15

**Only configuration 12



DHW+Heating mode /
DHW priority mode



Auto mode



Heating only mode



DHW only mode

5.2. MANUAL TEST

Manual test is an option which enables testing of all parts of the boiler in order to check their function.

NOTE: submenus in "Manual test" menu depend of the enabled options in "Installation menu"

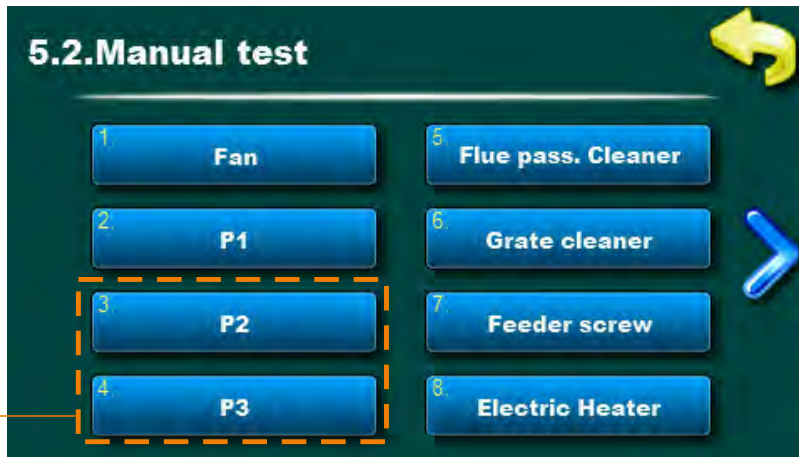

This appears depending on the configuration

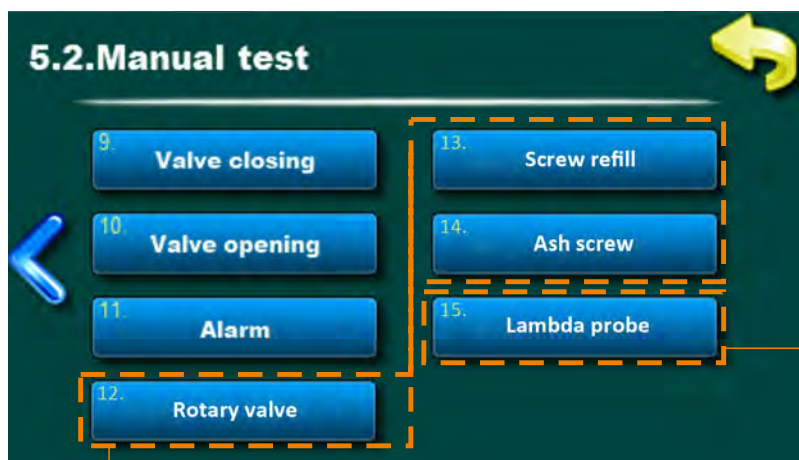
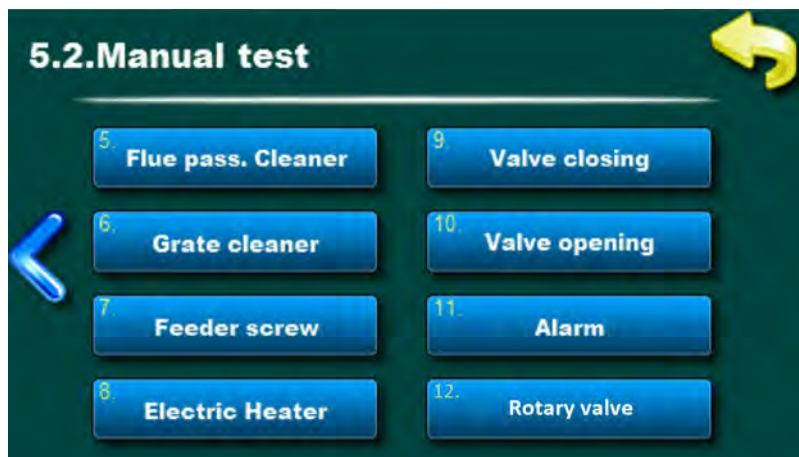

additional equipment

This only occurs with lambda probe boilers

MANUAL TEST IS POSSIBLE ONLY WHEN THE BOILER IS SWITCHED OFF

5.2.1. FAN

Possible selection:

START 1700 rpm - fan speed must be 1700 rpm

START MAX - fan speed must be on maximum (cca. 2800 rpm)

It is necessary to press the "START" next to the corresponding symbols and check if the fan operates according to the selected option (1700 rpm or cca. 2800 rpm). After pressing the "STOP" fan will turn off. Each time you press "START" it becomes "STOP" and vice versa. The display will rotate the fan symbol and will be displayed which speed spinning when the option is active.

5.2.2. - 5.2.4. P1, P2, P3

This options enables check of the work the connected pumps or diverter valve (P1, P2, P3).

It is necessary to press the "START" next to the corresponding symbol of the adequate pump and check to see if the pump is running. After pressing the "STOP" pump will stop working. Each time you press "START" it becomes "STOP" and vice versa. On display will be the symbol of the corresponding pump rotate when the option is active. Pump marks (P1, P2, P3) depend on the currently selected CONFIGURATION which is written on the screen.

5.2.5. FLUE GAS CHANNEL CLEANER

This option allows you to check the motor device of flue gas channel cleaner.

It is necessary to press the "START" next to the corresponding symbol and check that the motor device of flue gas channel cleaner will run turbulators. After pressing the "STOP", motor device will stop working. Each time you press "START" it becomes "STOP" and vice versa. Turbulators symbol is moving on display when the option is active.

5.2.6. GRATE CLEANER

This option allows you to check the motor device of grate cleaner.

It is necessary to press the "START" next to the corresponding symbol and check that the motor device moves burner grate. After pressing the "STOP" engine will return a burner grate in the work position, the burner grate is closed (0%). Each time you press "START" it becomes "STOP" and vice versa. When this option is active, symbol of burner grate is moving on display. When grate comes in one of two final positions, the main display shows the symbol "".

5.2.7. FEEDER SCREW

This option allows you to check the motor device of feeding screw.

It is necessary to press the "START" next to the corresponding symbol and check that the motor device of the feeding screw is working. After pressing the "STOP" engine will stop working. Each time you press "START" it becomes "STOP" and vice versa. When the option is active, on display will move a symbol of the pellet feeding screw and will show animation falling pellet boiler.

5.2.8. ELECTRIC HEATER

This option allows you to check electric heater.

It is necessary to press the "START" next to the corresponding symbol and check if the electric heater is working. After pressing the "STOP" electric heater will stop working. Each time you press "START" it becomes "STOP" and vice versa. The display will show animation of the electric heater when the option is active. **In this option, when the electric heater is working, then also and fan is working (fan symbol rotates when the option is active).**

5.2.9. VALVE CLOSING

This option allows you to check the motor device of 4-way mixing valve.

It is necessary to press the "START" next to the corresponding symbol and check if the motor device of 4-way mixing valve is working. Motor device should close the 4-way mixing valve. After pressing the "STOP" motor device will stop working. Each time you press "START" it becomes "STOP" and vice versa. The display will show the symbol of (closing) motor device when the option is active.

5.2.10. VALVE OPENING

This option allows you to check the motor device of 4-way mixing valve.

It is necessary to press the "START" next to the corresponding symbol and check if the motor device of 4-way mixing valve is working. Motor device should open the 4-way mixing valve. After pressing the "STOP" motor device will stop working. Each time you press "START" it becomes "STOP" and vice versa. The display will show the symbol of (opening) motor device when the option is active.

5.2.11. ALARM

This option allows you to check the work of sound/light alarm CAL (not included in delivery).

It is necessary to press the "START" next to the corresponding symbol and make sure that it works properly. It can be particularly checked for errors and fuel level.

5.2.12. - 5.2.14. ROTARY VALVE/SCREW REFILL/ASH SCREW





This option allows you to check the operation of the additional equipment (Rotary valve, Screw refill, Ash screw (69/96 only)) depending on what is installed on the boiler. Press the "START" button and check that the motor of the selected additional equipment is running. Pressing the "STOP" button will stop the motor. Each time you press the "START" button, it becomes "STOP" and vice versa. On the screen, the symbol for the selected additional equipment will be active when the option is active. Additional equipment (Rotary valve, Screw refill, Ash screw (69/96 only)) can be configured and connected to outputs P2, P3 or P4 (at the back of the boiler) depending on the heating configuration selected and the remaining available outputs.

5.2.15. LAMBDA PROBE





This option allows checking the operation of the lambda probe. Before activating this option you need to:

- make sure that the boiler room is ventilated (not smoked) (otherwise the result of this test lambda probe will not be accurate (the wrong information on the control screen will be displayed))
- all boiler doors are open

Entering this option, you need to press the "START" button and wait for the control Unit to do a lambda probe test.

The test result can be written „“ (green) or „“ (red) . If „“ is printed the lambda probe works correctly and you have successfully completed the lambda probe test. If „“ is displayed, you must repeat the test with additional preparations to perform this test. Press the "STOP" button.

If „“ was written perform additional actions before repeating the test:

- remove the upper boiler cover to ensure that fresh air enters the chimney from the room and does not smoke from the boiler or chimney. Press the 'START' button and wait for the control unit to perform the lambda probe test. The test result can be written „“ or „“ . If „“ is printed the lambda probe works correctly and you have successfully completed the lambda probe test. If „“ , is displayed and you are sure that you have followed all of the above procedures, call an authorized service technician for the test.

5.3. CHIMNEY SWEEPER

This option allows the flue gas measurement at different boiler powers. When this option is turned on, counter will appear on display. Time will start counting when the boiler reaches selected power (Dx). Text of the counter is red. When the boiler reach the selected power (Dx) and is on selected power for set time and factory set temperature of the boiler is achieved counter turns green and flue gases can be measured.

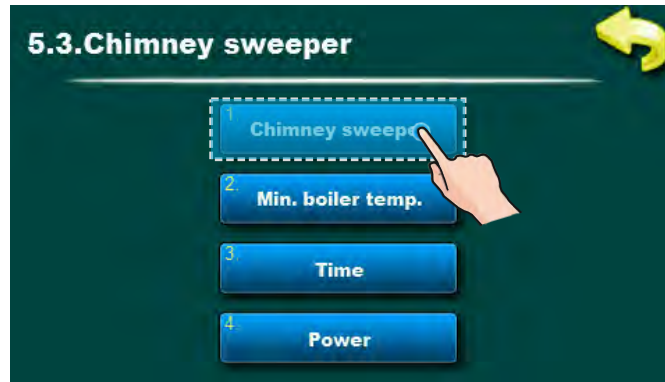

When this option is turned ON, button "BOILER OPERATION DISPLAY" becomes a button "CHIMNEY SWEEPER" (1). Pressing this button directly opens the menu "CHIMNEY SWEEPER" (without the need for scrolling through the menus). In this menu, is access to change parameters of "CHIMNEY SWEEPER" menu.

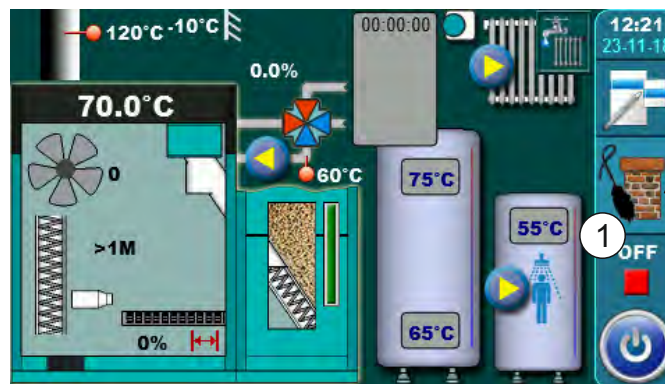

Shortcut

5.3.2 MIN. BOILER TEMPERATURE

The factory set temperature that must be achieved to start measuring (except for conditions that can be changed - boiler power and time).

- the minimum boiler temperature: min. 60°C - it can't be changed

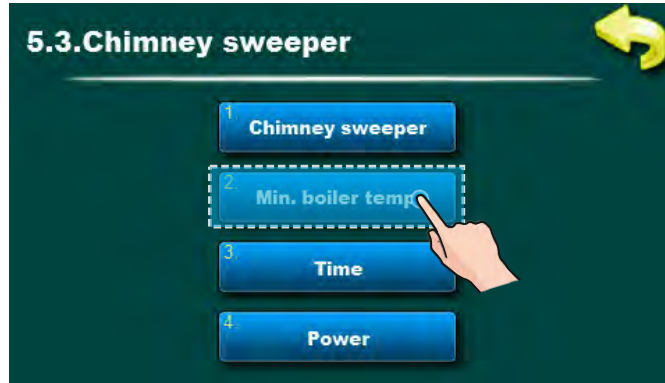

5.3.3 TIME

Possible selection:

Factory: 600 sec

Minimum: 600 sec

Maximum: 3600 sec

After the set parameters are met there is min. time to stabilize the flame before measuring. This time begins to run when the boiler is on selected power Dx and minimum boiler temperature.

After the expiration of this time the text of the counter becomes green (1) and only then is allowed to start measuring.

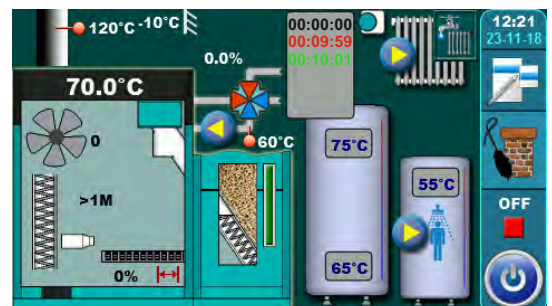
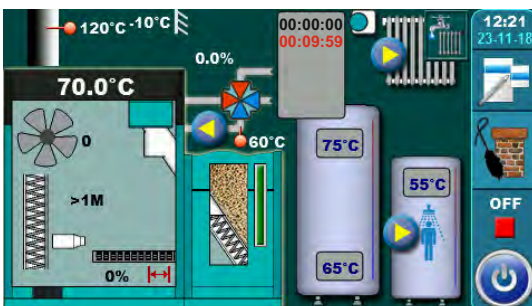
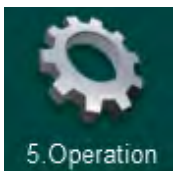

5.3.4 POWER

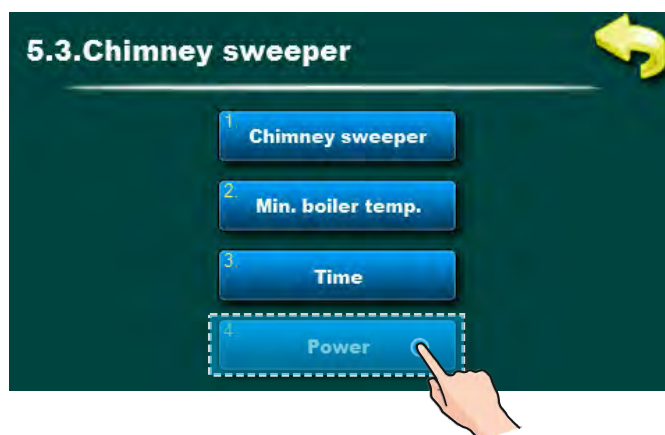
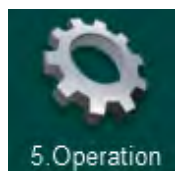

Possible selection:

Factory: D6 ~ 100% (maximum power)

Possible selection:

- D2 ~ 25% (minimum power)
- D3 ~ 45%
- D4 ~ 65%
- D5 ~ 85%
- D6 ~ 100% (maximum power)

This option allows the boiler to work in different powers in order to measure the flue gases in the boiler modulation phases. The boiler works on the selected power so long as the option is turned off, or the boiler temperature reach 3°C less than the set maximum temperature of the boiler (in this case the boiler reduces power). The boiler always achieves a nominal power D6 ~ 100% and then goes to the selected modulation power.



IMPORTANT!

When is turned ON option "Chimney sweeper":

- external control switches OFF automatically. After turning OFF the "Chimney sweeper" option, boiler continues to work according to the requirements of external control. If an external control doesn't request burner work, then the burner shuts down, otherwise burner will continue to work.
- boiler shutdown due to grate cleaning option is disabled automatically when "Chimney sweeper" option is enabled.

5.4. FORCED SHUTDOWN

This option is used to forced stop all processes.

First must be pressed the ON/OFF button to put the boiler in shutdown procedure and then "forced shutdown" button. All processes are stopped. After activating this option, it is necessary to clean the burner grate before restarting.

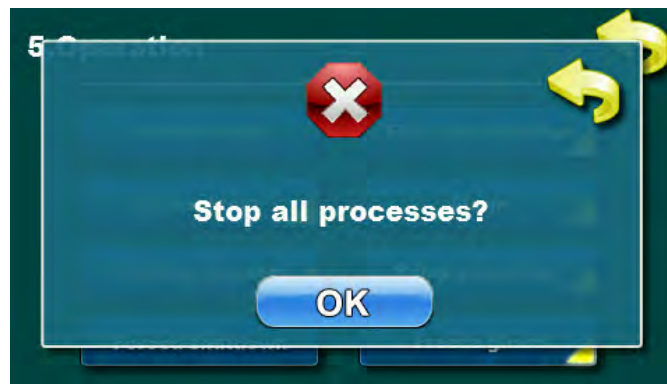
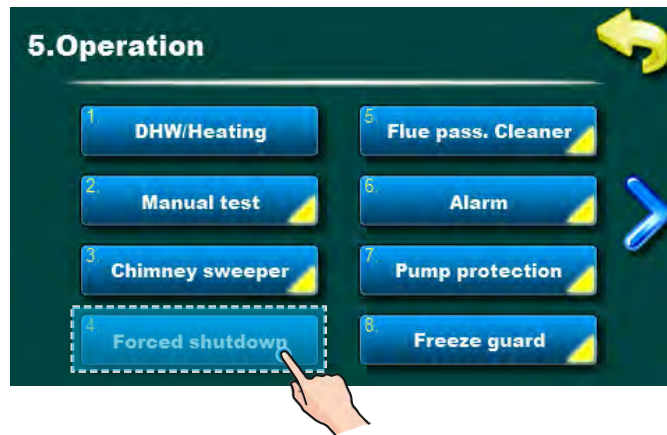
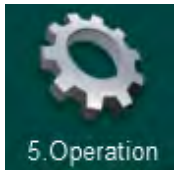

IMPORTANT! To be able to stop all processes, you must first turn off the boiler in the usual way by pressing  and then STOP.

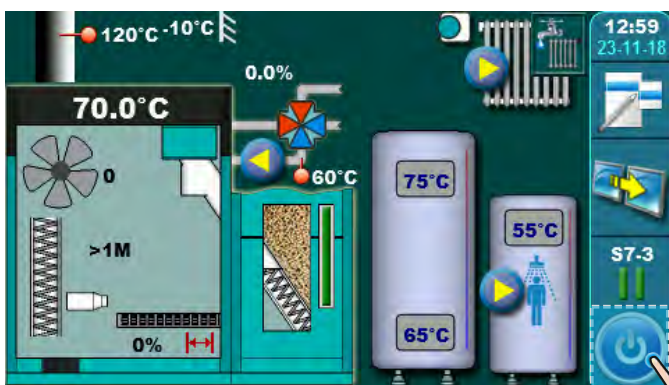

5.5. FLUE PASS. CLEANER

This option is used to disable working of flue gas passages cleaning (eg. in the night to prevent noise).

In times that are placed in the table is prevented clean flue passages. Times can be adjusted in the table in the same way as in table "Schedule".

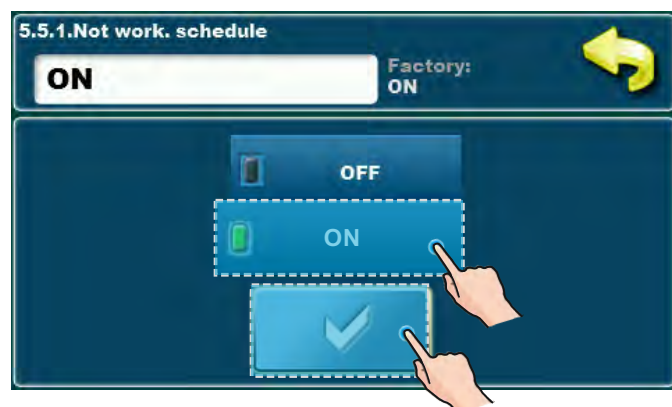
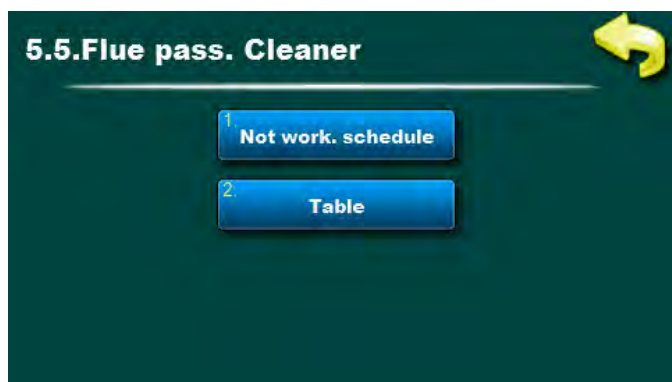

Flue pass. Cleaner - Table

	MON	TUE	WED	THU	FRI	SAT	SUN
1	00:00	00:00	00:00	00:00	00:00	00:00	00:00
	07:00	07:00	07:00	07:00	07:00	07:00	07:00
	19:00	19:00	19:00	19:00	19:00	19:00	19:00
	23:59	23:59	23:59	23:59	23:59	23:59	23:59

2

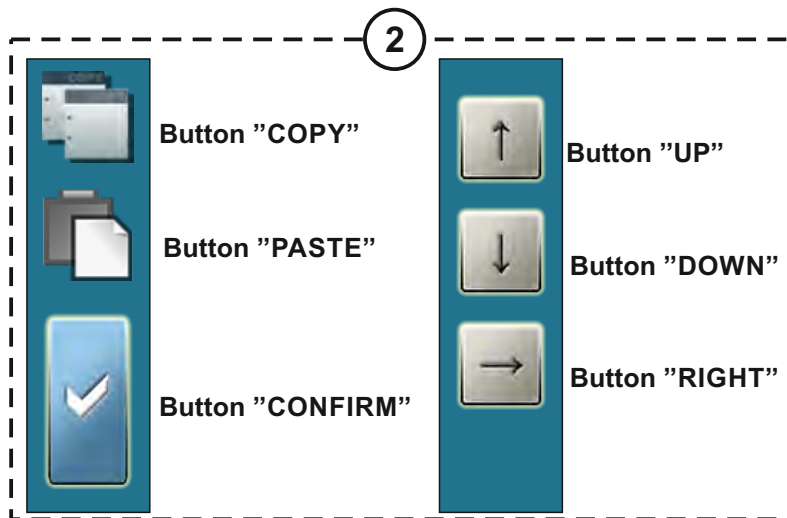
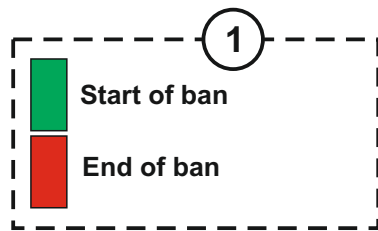

According to the data in the table, cleaning the flue passage is banned from 0:00 to 7:00 and from 19:00 to 21:00 every day of the week. This means that boiler will clean the flue passages only during the period from 07:01 to 18:59. Table can be adjusted according to the needs in the same way as the table "Schedule" (see 3.2-3.4).

5.6. ALARM (CAL - additional equipment)

This option is used to report errors or fuel level warning by speaker or lamp when the user isn't near of the boiler. (speaker and lamp are additional equipment and they must be installed only by an authorized person).

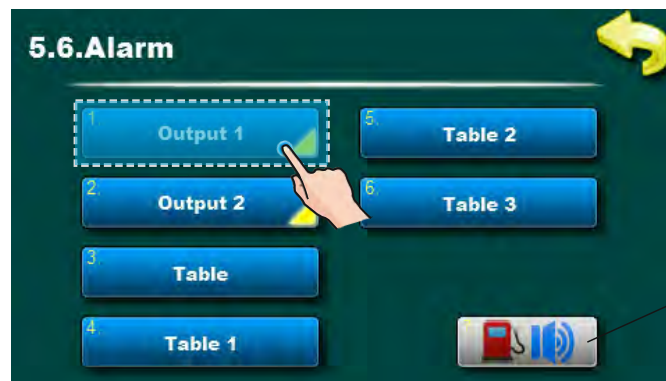
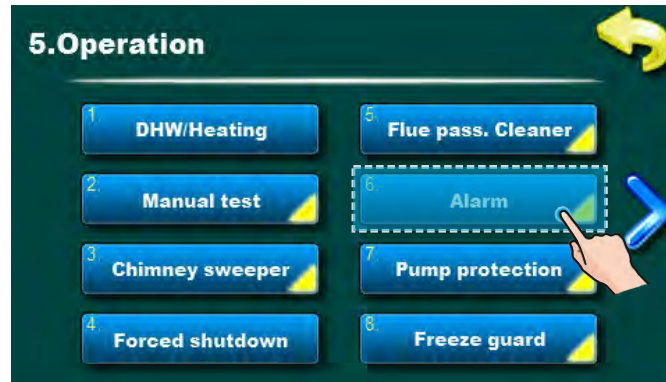
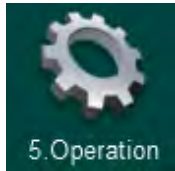

* Shortcut for disabling speaker for low fuel level warning



* By pressing this button user can disable/enable the fuel level warning sound from the speaker. (It refers only to warning about the low fuel level in the tank when speaker is selected as connected device). If only lamp is connected and selected as connected device, this shortcut is not displayed.

When speaker is disabled, this symbol becomes .

5.6.1.1 ERRORS

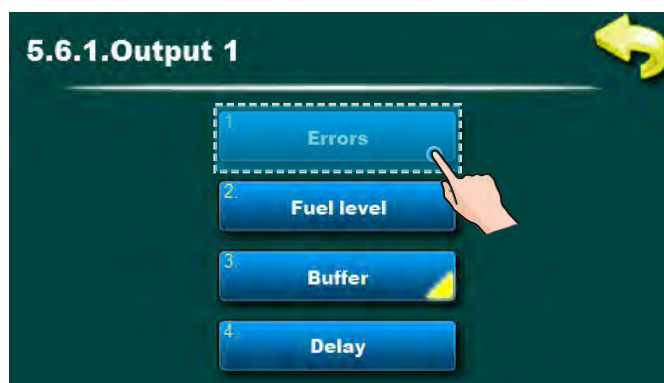
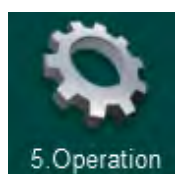

Possible selection:

Factory: OFF

Off, Continuous, Fast 1 time, Fast 3 times, Slow 1 time, Slow 3 time, Table

This parameter determines whether the output 1 errors occur. By selecting certain types of signals will be activated in the selected signal format.

5.6.1.2 FUEL LEVEL

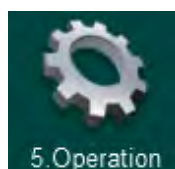

Possible selection:

Factory: OFF

Off, Continuous, Fast 1 time, Fast 3 times, Slow 1 time, Slow 3 time, Table

This parameter determines whether the output 1 fuel level warning occur. By selecting certain types of signals will be activated in the selected signal format.

5.6.1.3 BUFFER TANK (buffer tank low temperature)

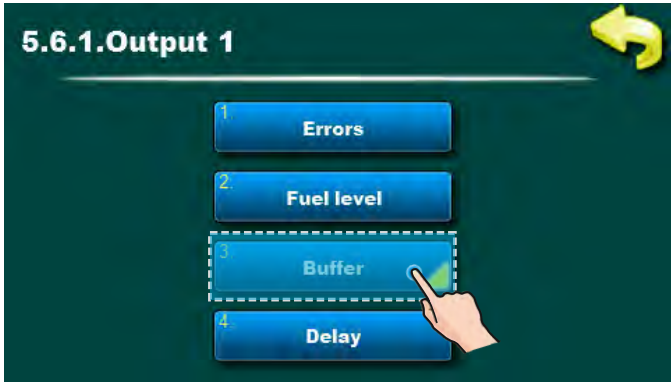

Possible selection:

Factory: OFF

Off, Continous, Fast 1 time, Fast 3 times, Slow 1 time, Slow 3 time, Table

This parameter define whether will it output 1 report warning for low temperature in buffer tank. This option don't allow setting of his own table for signal type in different time of day, but adjusted table for fuel level warning can be used. For using table for low temperature in buffer tank is necessary to activate table for fuel level (see Figure below).

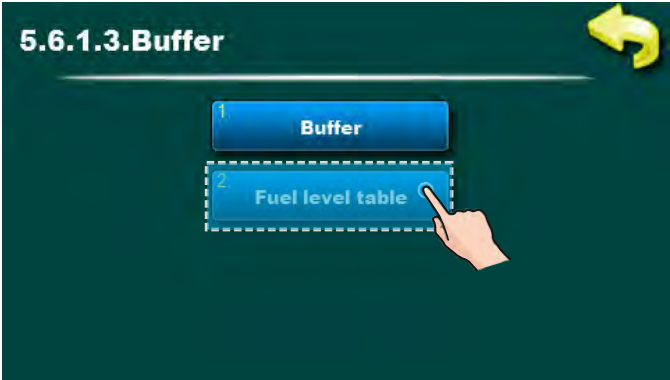
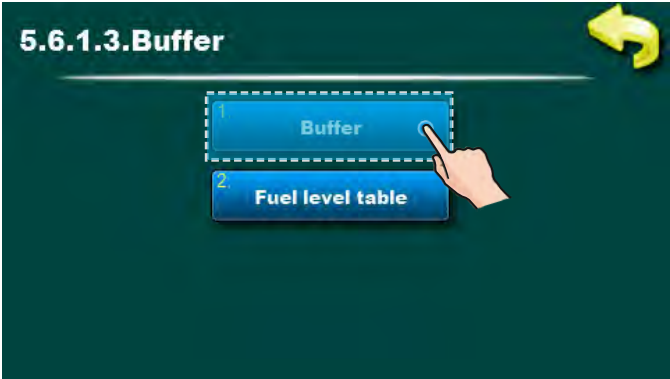

5.6.1.3 DELAY

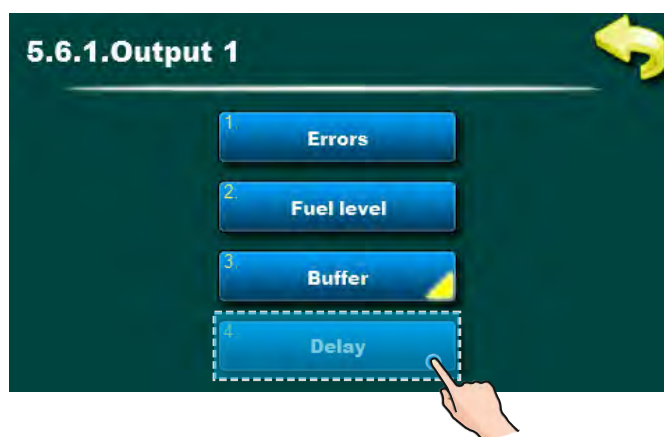
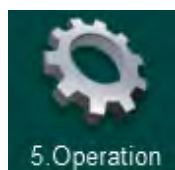

Possible selection:

Factory: 20 sec

Minimum: 5 sec

Maximum: 3600 sec

This parameter determines interval of signal repeating.

(This parameter will be ignored if the selected signal is "continuous").

In the same way it is possible to adjust the parameters of the output 2 (5.6.2)

5.6.3 TABLE

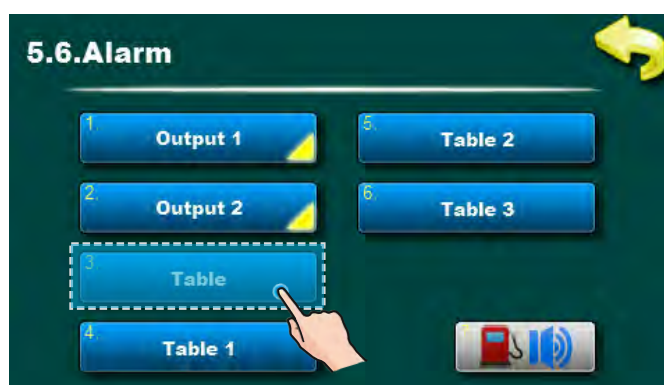
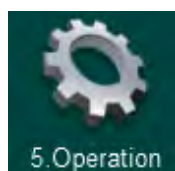

Factory: Table 1

Table 1, Table 2

This parameter is used to select the predefined table for the alarm. The automatic switching on and off or changing the signal type at a specific time. It is possible to adjust signal type for speaker and signal type for low fuel level warning. The table will be operational only if is "table" selected in point 5.5.1.1 for output 1 (signal type) or in point 5.5.2.1 for output 2 (signal type).

5.6.4 TABLE 1

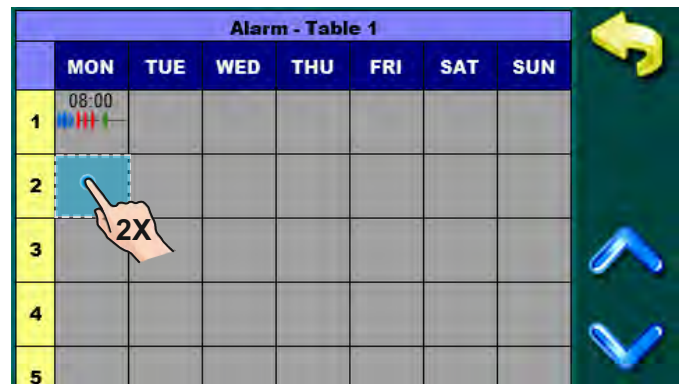

① Type of alarm alert



Lamp



Speaker

② Time

③ Symbol for alarm of boiler errors.

④ Symbol for alarm of fuel level warning

⑤ Signal type of boiler errors alarm.

⑥ Signal type of fuel level warning

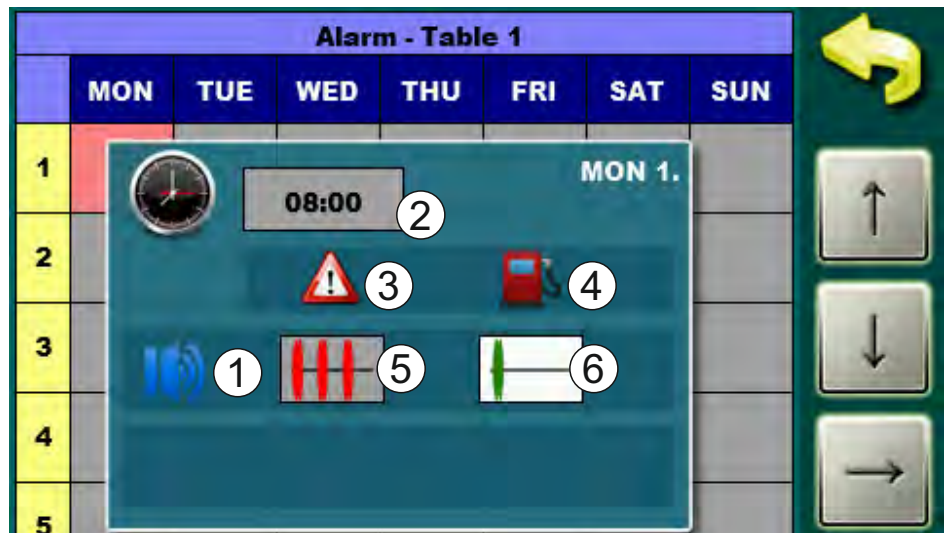

Setting values on table 1

Using the table to turn on or of and change type of signal for alarm or low fuel level warning at different times and days. When you enter the editing table, it is necessary to press 2 times the desired box (day) and then opens a new window where you can turn on and off, set signal type for boiler error, fuel level warning and the time at which the selected signal type takes effect. Eg. to change the time, it is necessary to press the box with time. When pressed on the box with time, its background becomes white and then it is possible to change the parameters by pressing the "up" and" down" (). It is possible to specify the type of signal 16 changes per day.





On the next page are described all symbols for types of signal. In the same way, you can fill table 2 (table 3 is not used).







The type of connected device (lamp or speaker) can be set only in installation menu, only by an authorized person.

Symbol descriptions (signal types)

For boiler error alarm (red)

Symbol	Description
—	Off
	Continuous
	Fast 1 time
	Fast 3 times
	Slow 1 time
	Slow 3 times

For fuel level warning (green)

Symbol	Description
—	Off
	Continuous
	Fast 1 time
	Fast 3 times
	Slow 1 time
	Slow 3 times

Example of filled table

	MON	TUE	WED	THU	FRI	SAT	SUN
1	00:00	00:00		15:00			
2	06:00						
3		12:00					
4							
5							







 Page up / down

According to table alarm is off on monday in 00:00, then is turned on in 06:00 (fast 3X for boiler error and fast 1X for fuel level warning). This way to alert the alarm goes until 00:00 tuesday when switched off again. In tuesday 24:00 alarm is active again (continuous for boiler error and 3X slow for fuel level warning. This way of alert alarm is active all day wednesday (day and night) until thursday at 15:00 when the alert alarm type changes (continuous for errors and fast 3X for fuel level warning. This way of alert alarm is valid on friday, saturday and sunday until monday at 00.00 when start a new table circuit.

Note: Delay between two alarm indication can not be changed in the table, but it can be set in the alarm menu as described in point 5.6.1

5.7. PUMP PROTECTION

This option enables protection of the pumps/valves from blocking during long stand-still (usually during summer season when heating is off).

Factory this option is enabled and max. stand-still time of outputs is set to 48 hours. According to this setting, any pump/valve output that is not activated in 48 hour, it will be activated for duration of 60 seconds. When certain output is activated it's stand-still time is reset.

NOTE: this function to be active, boiler must be connected to the power supply and main switch must be ON.

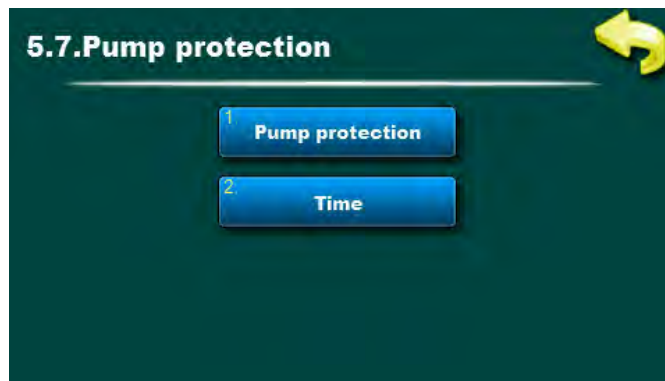
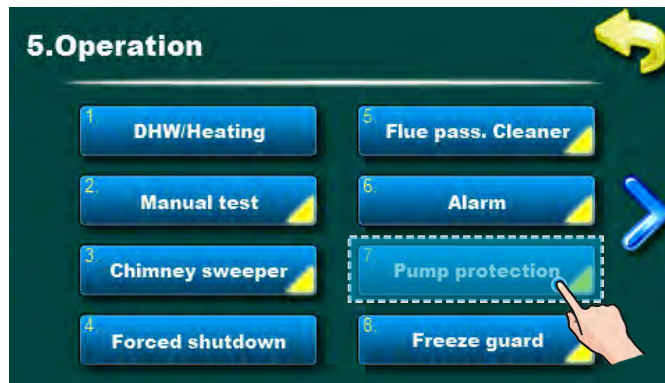
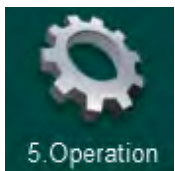

5.8. FREEZE GUARD - available from software version "v2.85"

This option is used to enable or disable Freeze guard option and to set its options. Freeze guard option can work with or without outdoor sensor.

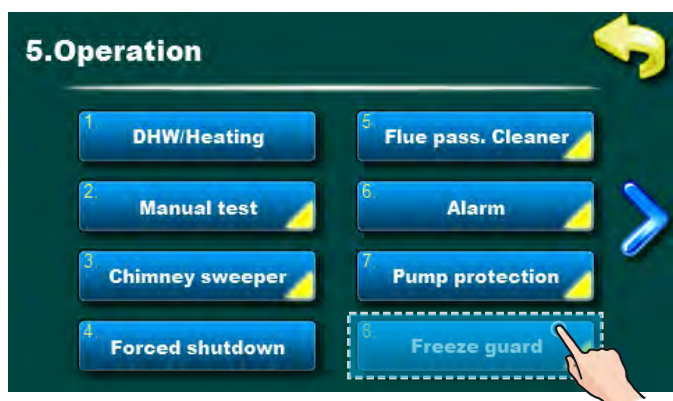

Freeze guard

Factory: OFF / **Options:** OFF / ON

Possibility to disable or enable Freeze guard option

Toutside

Factory: ON / **Options:** OFF / ON

Possibility to enable or disable outdoor sensor (can be changed only in the Installation menu (PIN))

Option

Factory: nothing selected / **Options:** Boiler, Direct circuit 1, Direct circuit 2, DHW, Circuits 1-8 (Cm2K)

Enabling/disabling monitoring of sensor temperatures of system items. Possible selection depends of the set configuration and installed additional equipment. If set conditions in Freeze guard/Temperatures menu are met, Freeze guard option will be activated for selected system items.

Temperature

Tsensor_min: factory: 5°C / **minimum:** 3°C / **maximum:** 10°C

Setting the sensor temperature at which Freeze guard will be activated for selected system items (can be changed only in the Installation menu (PIN)).

dTsensor_min: factory: 5°C / **minimum:** 2°C / **maximum:** 15°C

Setting the temperature difference after which Freeze guard option will be deactivated (can be changed only in Installation menu (PIN)).

Toutside_min: factory: 0°C / **minimum:** -5°C / **maximum:** 5°C

Setting the outdoor temperature at which Freeze guard option will be activated.

5.9 FUEL LEVEL



Possible selection: OFF (factory), ON

This option shows the approximate amount (volume) of pellets in the pellet tank in "%" with considering to the total volume of the container. Using this option only makes sense if the user, after COMPLETELY FILLS the pellet tank, presses the "RESET" button located on the main screen at the top of the pellet tank view (if ON) (see page 4. "29 - Fuel level percentage reset button (if FUEL LEVEL is ON)"). This option is independent of the warning W1 FUEL LEVEL and error E22 FUEL LEVEL.

Note:

"Fuel level" and "Suction system" or "Screw refill" cannot be enabled simultaneously

5.9. SUCTION SYSTEM



This option is used to set pellet delivery vacuum suction system.

For details refer to Suction system manual.

Note:

"Suction system" and "Fuel level" or "Screw refill" cannot be enabled simultaneously.

5.10. INTERNET SUPERVISION - available only from firmware version "v2.82m"

IMPORTANT NOTES:

i CM WiFi-box requires active DHCP server of Access Point (e.g. router) because manual setting of network parameters is not possible. For more informations contact administrator of your home network.

i To be able to use Cm WiFi box on PelTec/PelTec Lambda boiler, minimum required firmware versions of the boiler regulation must be: "v2.82m_30" / "v2.82m_30L" "v2.82m_270" / "v2.82m_270L"
Boiler version is displayed in the "INFO" menu.
If there is older firmware version, it must be updated to be able to use Cm WiFi box.
For firmware update please contact authorized serviceman.

i For detailed configuration of the Cm WiFi box please refer to the Cm WiFi box manual received with the Cm WiFi box.

This option is used to set the regulation to connect boiler to the internet through local Wi-Fi network.

This option is used to change internet supervision settings.

This option is only visible if "Cm WiFi box" is connected to the boiler regulation by UTP cable.

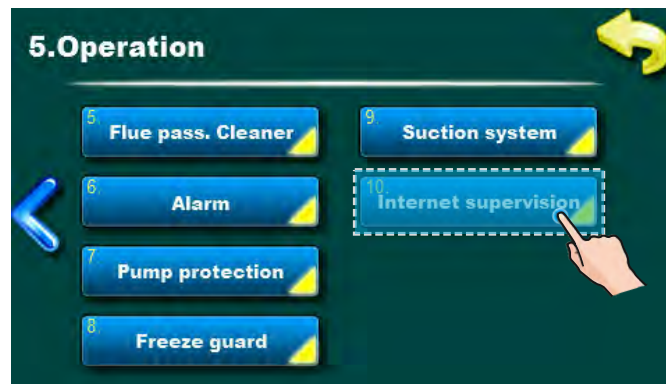

When "Cm WiFi box" is connected to the boiler and internet supervision is enabled, a new icon appears on the main screen showing the status of internet supervision.

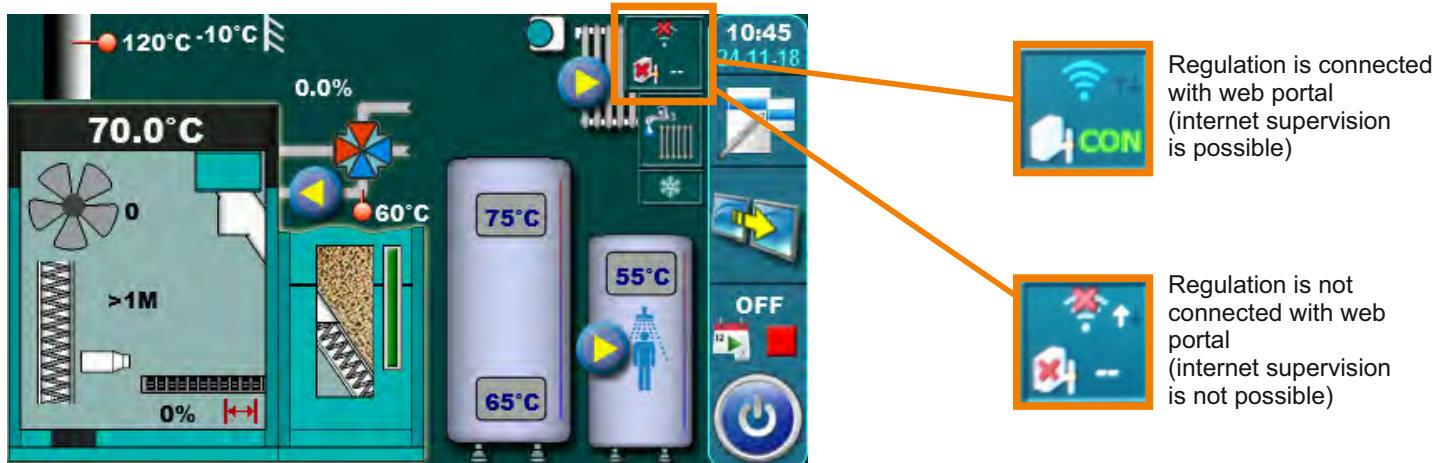

Internet supervision (additional equipment)

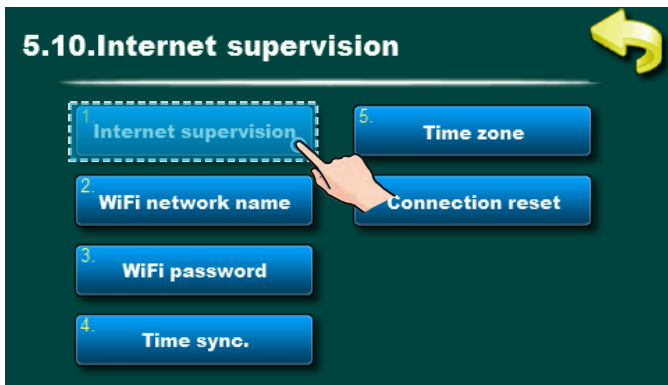

Factory: Supervision + control
OFF, Supervision, Supervision + control

This option is used to set and enable/disable internet supervision.

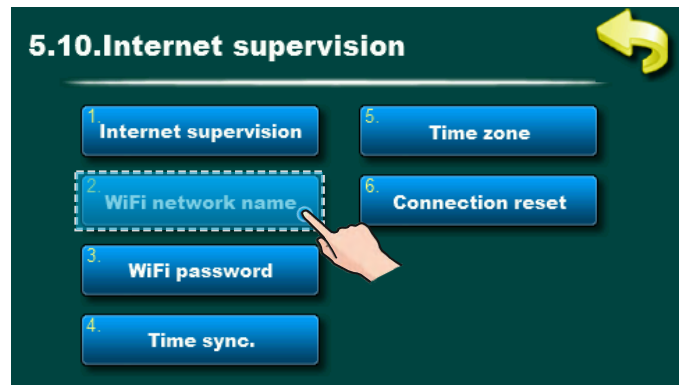

This option allows you to enter the name of WiFi home network to which you want to connect the "Cm WiFi box" and the boiler. You must enter exact WiFi network name or else boiler will not be able to connect to the WiFi network.

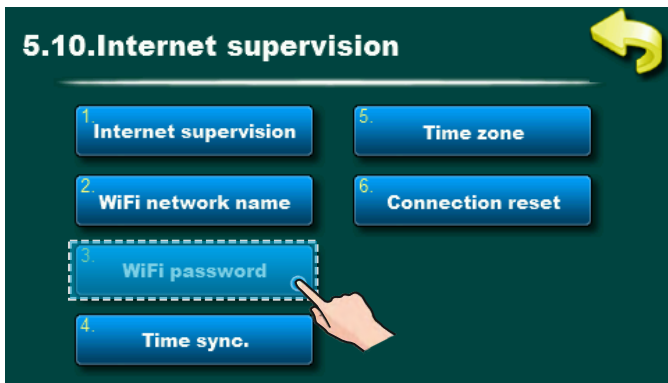

This option allows you to enter a password for your home Wi-Fi network. You must enter exact password or else boiler will not be able to connect to the WiFi network.

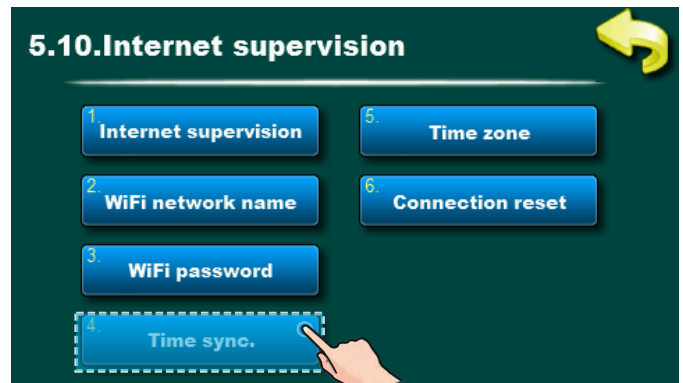

This option allows boiler time synchronization with web server time (internet time).

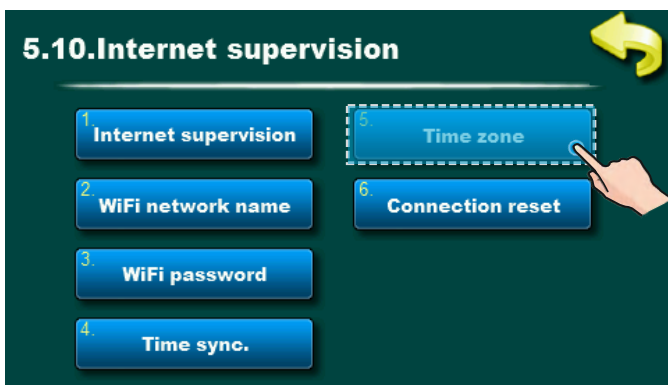

This option allows you to set the time zone if the boiler is in a different time zone than the web portal server. (this option must be set if you enable "Time synchronisation option")

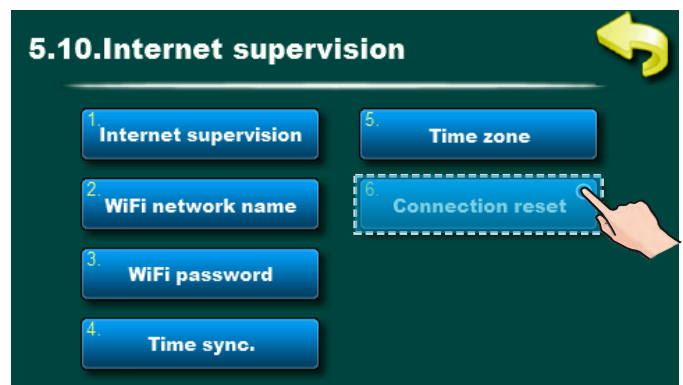

This option allows you to reset connection with home network.

6.0. DATE AND TIME



This option is used to set the date and time. This option is used to set the date and time. It is necessary for starting times, and the recording of errors / warnings (for the occurrence of errors / warnings, remembers the date and time of occurrence). After setting the date and time it is necessary to press the "CONFIRM" for saving date and time. If there is a significant clock delay or clock setting at 00:00 or the date on 1.1.2000. It is necessary to replace the battery on the back of the display (battery type CR 1220).

7.0. DISPLAY



7. Display:

- | | |
|-------------------------|-------------------|
| 7.1. Screensaver | 7.4. Sound volume |
| 7.2. Language selection | 7.5. Sound type |
| 7.3. Welcome time | |

7.1. SCREENSAVER

Possible selection: **Default: 600 seconds** Minimum: 10 seconds Maksimum: 3600 seconds
If at some time nothing was pressed on the screen, the screensaver will turn on, to prevent damage on the screen. Once you touch the screen, the screensaver will turn of.

7.2. LANGUAGE SELECTION

Possible selection: Enabled (**default**), Disabled

This option enables or disables screen with the choice of language regulation when you turn-on main switch. If is marked "DISABLED", after turning-on the main switch, it will be set on before selected language and after some time, display will show the work display of the boiler (duration of this screen can be adjusted in Section 7.3.).

7.3. WELCOME TIME

Possible selection: **Default: 5 seconds** Minimum: 0 seconds Maximum: 20 seconds

This option is used to set the desired duration of the initial message after turning on the main switch. This option is only available if the option" LANGUAGE SELECTION" (point 7.2.) Is set to"DISABLED".

7.4. SOUND VOLUME

Possible selection: **Default: Volume 3**, OFF, volume 1, volume 2, volume 3

This option is used to set speaker volume.

7.5. SOUND TYPE

Possible selection: **Default: Type 1**, Type 1, Type 2, Type 3, Type 4 , Type 5, Type 6, Type 7, Type 8, Type 9, Type 10

This option is used to adjust type of speaker sound. It is possible to choose between 10 different types of sounds.

8.0. FILE

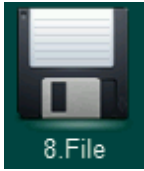

8. FILE:

- 8.1. LOAD FACTORY
- 8.2. SAVE

- 8.3. LOAD

8.1. LOAD FACTORY

After pressing "LOAD FACTORY" you will see a message "LOAD FACTORY SETTINGS?". Pressing button "OK" will load the default settings of regulation. Pressing the "BACK" will return to the previous menu.

8.2. SAVE

After pressing "SAVE" you will see a message "SAVE CURRENT SETTINGS?". Pressing button "OK" the current setting of regulation will be saved in memory. Settings can be saved in three different memory places (memory 1, memory 2, memory 3). Pressing the "BACK" will return to the previous menu.

8.3. LOAD

Settings can be loaded from one of 3 different memories in which the settings are saved. After pressing "LOAD" you will see "LOAD SAVED SETTINGS?". Pressing button "OK" saved settings (saved in option SAVE) will be loaded. Pressing the "BACK" will return to the previous menu.

9.0. STATISTIC



Statistics of boiler operation and certain parts:

- | | | | |
|---------------|------------------|------------|------------|
| - Burner work | - Fan | - Power D6 | - Power D2 |
| - Starting | - Heater | - Power D5 | - Power D1 |
| - F. Screw | - Vacuum turbine | - Power D4 | - Power D0 |
| - Flame | - Vacuum cycles | - Power D3 | |

The regulation follows the startup number of the boiler and the work time of certain parts of the boiler.

10.0. INSTALLATION



MENU ONLY FOR AUTHORIZED SERVICE

11.0. INFO



Menu with general information:

- Software version
- Boiler Power
- WiFi ID

12.0. REGULATOR (CM2K)





This option is only visible if it is activated in "Installation men." Access to the Installation menu has only authorized person (by entering PIN). For more informations about this menu see "Technical instructions, Module for control of two heating circuits (CM2K)".

13. ADDITIONAL

13.1 EXTERNAL CONTROL

Only authorized serviceman can enable external control ("Installation menu") only in the following configurations:

	External control connected to:	
Configuration 4:	BUF	S6
Configuration 6:	BUF--IHC	S6
Configuration 8:	BUF--DHW	S6
Configuration 9:	BUF--IHC DHW	S6
Configuration 10:	CRO	S6
Configuration 11:	CRO/BUF	S9
Configuration 14:	BUF--IHCX2	S6

When external control is connected and configured in "installation" menu, symbol  /  appears in main screen.

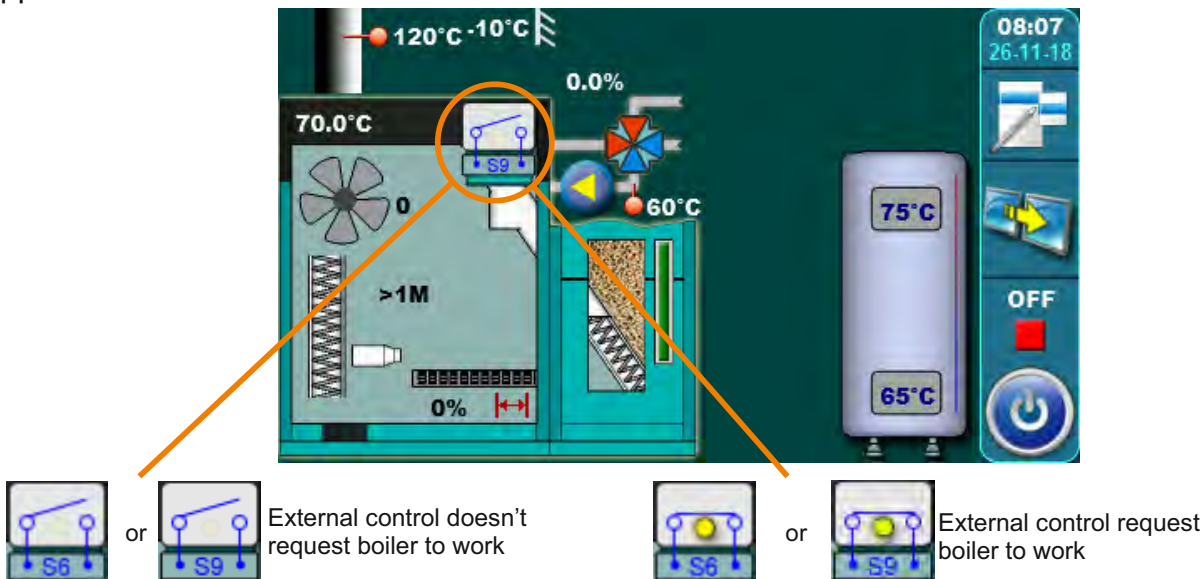

External control doesn't request boiler to work

External control request boiler to work



IMPORTANT!

After enabling external control, boiler must be manually started by ON/OFF button. After start, regulation begins to monitor demand from external control and according to it, starts/stops the boiler. If boiler is switched off by ON/OFF button, boiler will switch off (OFF) and won't monitor demand from external control. When boiler is started by ON/OFF button and there is demand from external control, boiler will start, if there isn't external control demand boiler will enter standby/pause mode (S7-3) and waits for demand.



OFF

STANDBY/ PAUSE

ON

Table of sensors resistances

TABLE OF RESISTANCES OF
NTC 5K/25°C SENSOR
Measuring range from -20 to +130°C
Used as:

Boiler temp. sensor,
DHW temp. sensor,
Main flow temp. sensor
Return flow temp. sensor,

Temp. (°C)	Resistance (Ω)
-20	48.535
-15	36.465
-10	27.665
-5	21.158
0	16.325
5	12.694
10	9.950
15	7.854
20	6.245
25	5.000
30	4.028
35	3.266
40	2.663
45	2.184
50	1.801
55	1.493
60	1.244
65	1.041
70	876,0
75	740,7
80	629,0
85	536,2
90	458,8
95	394,3
100	340,0
105	294,3
110	255,6
115	222,7
120	190,7
125	170,8
130	150,5

TABLE OF RESISTANCES OF PT1000 SENSOR
Measuring range from -30 to +400°C
Used as:
Flue gas temp. sensor

Temp. (°C)	Resistance (Ω)	Temp (°C)	Resistance (Ω)
-30	885	190	1.732
-25	904	195	1.751
-20	923	200	1.770
-15	942	205	1.789
-10	962	210	1.809
-5	981	215	1.828
0	1.000	220	1.847
5	1.019	225	1.866
10	1.039	230	1.886
15	1.058	235	1.905
20	1.077	240	1.924
25	1.096	245	1.943
30	1.116	250	1.963
35	1.135	255	1.982
40	1.154	260	2.001
45	1.173	265	2.020
50	1.193	270	2.040
55	1.212	275	2.059
60	1.231	280	2.078
65	1.250	285	2.097
70	1.270	290	2.117
75	1.289	295	2.136
80	1.308	300	2.155
85	1.327	305	2.174
90	1.347	310	2.194
95	1.366	315	2.213
100	1.385	320	2.233
105	1.404	325	2.251
110	1.424	330	2.271
115	1.443	335	2.290
120	1.462	340	2.309
125	1.481	345	2.328
130	1.501	350	2.348
135	1.520	355	2.367
140	1.539	360	2.386
145	1.558	365	2.405
150	1.578	370	2.425
155	1.597	375	2.444
160	1.161	380	2.463
165	1.635	385	2.482
170	1.655	390	2.502
175	1.674	395	2.521
180	1.693	400	2.540
185	1.712		

13.4 OPERATION STAGES (SHOWN ON THE SCREEN)

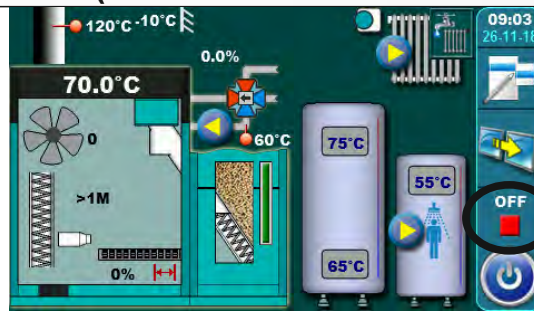

Boiler stage mark

OFF	Boiler is switched off
S0	Initial fan blowing, waiting for grate position check
S1	Not used
S2	Initial pellet filling
S3	Waiting for flame to appear
S4	Electric heater working after flame appears
S5	Flame developing stage
SP1	Stabilisation stage 1
SP2	Stabilisation stage 2
SP3	Stabilisation stage 3
SP4	Stabilisation stage 4
SP5	Stabilisation stage 5
S6	Additional flame developing stage
D0	Power D0
D1	Power D1
D2	Power D2
D3	Power D3
D4	Power D4
D5	Power D5
D6	Power D6
S7	Shuting down stage
S7-1	1st stage of shutting down stage, waiting for flame to dissapear and additional blowing for set time, after which S7-2 stage starts. Flue gas fan works (rpm) according to stage from which boiler entered S7-1 stage
S7-2	2nd stage of shutting down stage. Final flue gas fan blowing at. max rpms until factory set time passes. After this stage grate cleaning stage starts (C0) and enters S7-3 stage.
S7-3	Burner don't work/standby/pause. Boiler waits demand for start.
PF0	Stage after power supply failure and power supply return, el. heater is started and waits for flame to appear (if flame appears -> PF1, if flame don't appears -> PF4)
PF1	El. heater switches off and enter PF2
PF2	Flame developing stage, enter PF3
PF3	Waits for flame disappearing, enter PF4
PF4	Final flue gas blowing, boiler restarts or enters OFF stage, depending of the stage when power supply failure occurs
C0	Grate cleaning stage



Centrometal d.o.o. assumes no responsibility for possible inaccuracies in this book originated typographical errors or rewriting, all the pictures and diagrams are principal and it is necessary to adjust each actual situation on the field, in any case the company reserves the right to enter their own products such modifications as considered necessary.

Centrometal d.o.o. Glavna 12, 40306 Macinec, Croatia

central tel: +385 40 372 600, fax: +385 40 372 611
service tel: +385 40 372 622, fax: +385 40 372 621

www.centrometal.hr
e-mail: servis@centrometal.hr

Centrometal
HEATING TECHNIQUE
